



## OMFT - OPTICAL MULTI-FORMAT TRANSMITTER TRANSMITTER SOLUTIONS

### USER MANUAL



OMFT CLASS 40 & 60



OMFT CLASS 80

P/N OMFT-x-0x-FA  
x: Wildcard, applies to all instruments

Status: 2026-05-28  
Applies to Firmware 2.7.0 or later

info@id-photonics.com  
id-photonics.com

# CONTENT

1	General Information	3
2	Quick Start	7
3	Overview	10
4	Hardware Setup	17
5	Tunable Laser	21
6	User Interfaces – Touch Panel and Web Interface (WebGUI)	22
7	Remote Control	31
8	Appendix	51

# 1 GENERAL INFORMATION

## 1.1 COMPLIANCE STATEMENT ELECTROMAGNETIC COMPATIBILITY AND DEVICE SAFETY

Hereby, we declare that this system has been designed and tested for compliance for the following directives.

### 1.1.1 INTERNATIONAL

IEC 62368-1

CISPR 11:2003 in accordance with EN 61326-1: 2006

### 1.1.2 UNITED STATES OF AMERICA

FCC 47 CFR Part 15, Subpart B Class A, Measurement process ANSI C63.4 (2009)

### 1.1.3 EUROPEAN UNION

EN 55022:2011

EN 61326-1: 2013

EN 61000-6-2: 2006

EN 61000-6-4: 2011

EN 61000-3-2: 2010

EN 61000-3-3: 2009

This conformity statement for includes EU directive 2002/95/EG (RoHS) and EU directive EG1907/2006 (REACH).

## 1.2 LIMITATION OF COMMUNICATION INTERFACES

Operation of all USB Ports is limited to a maximum cable length of 3 m and a maximum length of 30 m for all Ethernet ports present.

## 1.3 EUROPEAN WEEE DIRECTIVE COMPLIANCE

ID PHOTONICS has established processes in compliance with the Waste Electrical and Electronic Equipment (WEEE) directive, 2002/96/EC. This product should not be disposed of as unsorted municipal waste and should be collected separately and disposed of according to your national regulations. In the European Union, all equipment purchased from ID PHOTONICS can be returned for disposal at the end of its useful life. ID PHOTONICS will ensure that all waste equipment returned is reused, recycled, or disposed of in an environmentally friendly manner, and in compliance with all applicable national and international waste legislation. It is the responsibility of the equipment owner to return the equipment to ID PHOTONICS for appropriate disposal. If the equipment was imported by a reseller whose name or logo is marked on the equipment, then the owner should return the equipment directly to the reseller. If you have questions concerning disposal of your equipment, contact ID PHOTONICS's at [WEEE@id-photonics.com](mailto:WEEE@id-photonics.com).

## 1.4 LINE VOLTAGE SELECTION

The unit operates from any single-phase AC power source that supplies 100 ~ 240 VAC at a frequency of 50/60 Hz. The input line voltage setting is done automatically by the internal power supply.

## 1.5 SERVICE

Do not attempt to service or adjust this instrument unless an authorized person is present. Do not install substitute parts or perform any unauthorized modifications to this instrument. Contact ID Photonics or your local distributor to obtain service support.

## 1.6 HELP AND USER FEEDBACK

ID Photonics GmbH is dedicated to continuously improve customer experience of our products. Thus, if you have any feedback that might help us to improve our products send us an E-Mail to: [feedback@id-photonics.com](mailto:feedback@id-photonics.com).

## 1.7 SAFETY

### 1.7.1 GENERAL SAFETY PRECAUTIONS

The following general safety precautions must be observed during all phases of operation of this instrument. Failure to comply with these precautions or with specific warnings elsewhere in this manual violates safety standards of design, manufacture, and intended use of the instrument.

ID Photonics assumes no liability for the customer's failure to comply with these requirements.

Before operation, review the instrument and manual for safety markings and instructions. You must follow these to ensure safe operation and to maintain the instrument in safe condition.

### 1.7.2 GENERAL

This product is a Safety Class 1 instrument (provided with a protective earth terminal). The protective features of this product may be impaired if it is used in a manner not specified in the operation instructions.

### 1.7.3 ENVIRONMENT CONDITIONS

This instrument is intended for indoor use in an installation category II, pollution degree 2 environment. It is designed to operate at a maximum relative humidity of 95% and at altitudes of up to 2000 meters.

Refer to the specification's tables in the inspection report for the ac mains voltage requirements and ambient operating temperature range.

### NOTE

Before connecting electrical power to the unit, make sure the unit could acclimatize to ambient temperature for at least 2 hours to avoid damage by i. e. condensed humidity on electrical parts inside the unit.

### 1.7.4 FUSE REPLACEMENT

For continued protection against the possibility of fire, replace the fuse only with a fuse of the specified voltage, current and type ratings.

### 1.7.5 BEFORE APPLYING POWER

Verify that all safety precautions are taken. The power cable inlet of the instrument serves as a device to disconnect from the mains in case of hazard. The instrument must be positioned so that the operator can easily access the power cable inlet. When the instrument is rack mounted the rack must be provided with an easily accessible mains switch.

### 1.7.6 MAXIMUM RATINGS

ALWAYS operate the unit within the maximum ratings listed. Ignoring these limits may result in permanent damage to the unit and loss of warranty.

### 1.7.7 GROUND THE INSTRUMENT

To minimize shock hazard, the instrument chassis and cover must be connected to an electrical protective earth ground. The instrument must be connected to the ac power mains through a grounded power cable, with the ground wire firmly connected to an electrical ground (safety ground) at the power outlet. Any interruption of the protective (grounding) conductor or disconnection of the protective earth terminal will cause a potential shock hazard that could result in personal injury.

### 1.7.8 DO NOT OPERATE IN AN EXPLOSIVE ATMOSPHERE

Do not operate the instrument in the presence of flammable gases or fumes.

### 1.7.9 DO NOT REMOVE THE INSTRUMENT COVER

Keep away from live circuits inside the equipment. Operating personnel must not remove equipment covers. Opening the instrument will result in loss of all warranty given for the instrument and may exhibit lethal health risks.

Only factory authorized service personnel or other qualified service personnel may remove equipment covers for internal subassembly or component replacement or any internal adjustment. Do not install substitute parts or perform any unauthorized modification of the equipment or the warranty may be voided.

Instruments that appear damaged or defective should be made inoperative and secured against unintended operation until they can be repaired by qualified service personnel.

### 1.7.10 VENTILATION

Keep a space of 30 cm or more between the rear side of the device and any other objects such as walls to guarantee sufficient cooling of the device.

Never block the air fan and ventilation openings.

### 1.7.11 CLEANING THE INSTRUMENT

To avoid personal injury, power down the device and disconnect it from line voltage before performing any of the following procedures.

To clean the exterior surface, perform the following steps:

Remove loose dust on the outside of the instrument with a lint-free cloth.

Use a soft cloth dampened with water to clean the device. Use 75% isopropyl alcohol solution as a cleaner.

Do not use any abrasive or chemical cleaning agents.

### 1.7.12 SAFETY SYMBOLS ON INSTRUMENTS

#### 1.7.12.1 WARNING OR CAUTION



If you see this symbol on the product, you must refer to the manual for specific Warning or Caution information to avoid personal injury or damage to the product.

#### 1.7.12.2

#### ESD SAFETY WARNING



This sign indicates that the respective modules, boards or RF inputs and outputs are susceptible to damage by electro static discharge (ESD), and require proper protection procedures for storage and handling. Refer to the manual for the necessary protection procedures.

#### 1.7.12.3

#### OUTPUT OF LASER RADIATION WARNING



This unit can contain an active source of laser radiation, if the option “internal laser source” is installed, that may cause harm to the eye. Please refer to section 0 for laser safety warning.

Please note that even if the unit has no internal laser source installed, it can be connected to external laser sources such that some ports can radiate laser light in such a configuration. Device output ports, which potentially emit laser radiation, are indicated by this sign:

#### 1.7.12.4 WEAR EYE PROTECTION

Wear eye protection if exposure to high-intensity rays or laser radiation exists.

#### 1.7.12.5 DO NOT DIRECTLY VIEW OPTICAL MODULATOR OUTPUT

Under no circumstances should you use any optical instruments to view the laser output (optional) or optical modulator output directly.



### 1.7.12.6

### WARNING LASER SAFETY

The laser sources specified by this user guide are classified according to IEC 60825-1 (2007) Laser Notice No. 50 dated 2007-June-24 and comply with CFR 1040.10 except deviations per Laser Notice No. 50, July 2001 Key Feature Number 4.

Do not view the laser output from this device directly with optical instruments (e.g., eye loupes, magnifiers, microscopes). Viewing the laser output with certain optical instruments within a distance of 100mm may pose an eye hazard. The class 1M laser product definition is based on all conditions defined in this section.

Please pay attention to the following laser safety warning: Under no circumstances look into the end of an optical cable attached to the optical outputs when the device is operational. The laser radiation can seriously damage your eyesight. Do not enable the laser when there is no fiber attached to the optical output ports. The laser is enabled by pressing the 'Laser on' button in the operating software delivered with the instrument. The laser is on when the virtual red LED in the front panel of the instrument is lit. The use of optical instruments with this product will increase eye hazard.

In doubt about laser safety requirements consult a trained laser safety instructor for local safety requirements of this product.

### 1.7.12.7 OPTICAL OUTPUT OF LASER PORT

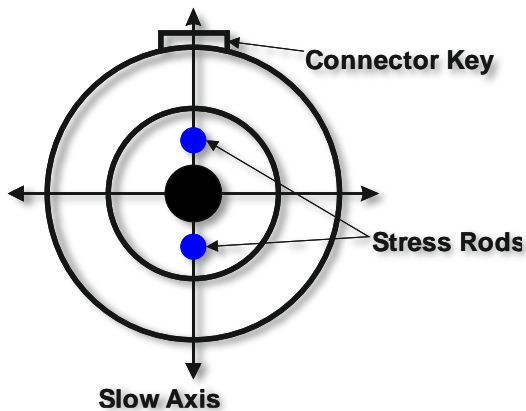

The laser port, only installed on devices containing the optional internal laser source, features a polarization maintaining fiber output which can be both used with standard single mode fibers and polarization maintaining fibers.

### 1.7.12.8 PRECAUTIONS WITH CONNECTORS

### PRECAUTIONS

It is essential to ensure that all optical and electrical connectors are in good condition. Dirty connectors can lead to poor performance, while broken connectors can cause damage to other equipment! Before using a microwave connector, check it visually, using an

optical microscope (20x magnification is recommended). If the connector needs to be cleaned, swab it with clean isopropyl alcohol. Dry the connector by blowing it with clean compressed air or nitrogen.

Microwave connectors must be tightened with a torque wrench. Overtightening connectors can damage the thread and render the connector unusable!

Before an optical connector is used, check it visually by using an optical microscope as recommended by the manufacturer of the connector. Please pay attention to the laser safety warning in section 0 before inspecting optical connectors. If the connector needs to be cleaned, apply the cleaning procedure recommended by the manufacturer of the connector.

Make sure you are familiar with these issues to avoid damage to your device and possible violation of warranty.

### ! NOTE

Before connecting the inputs or outputs to any measurement equipment or device under test, make sure that a suitable attenuator, if necessary, is fitted. The maximum levels of each individual input/output are shown in section 8

## 2 QUICK START

This section contains redundant information from other chapters but is useful for a first-time usage of the instrument.

- Insert power cord to power cord socket located at read side of the unit (6).

### ! NOTE

Do not turn-on OMFT, before hardware setup is completed!

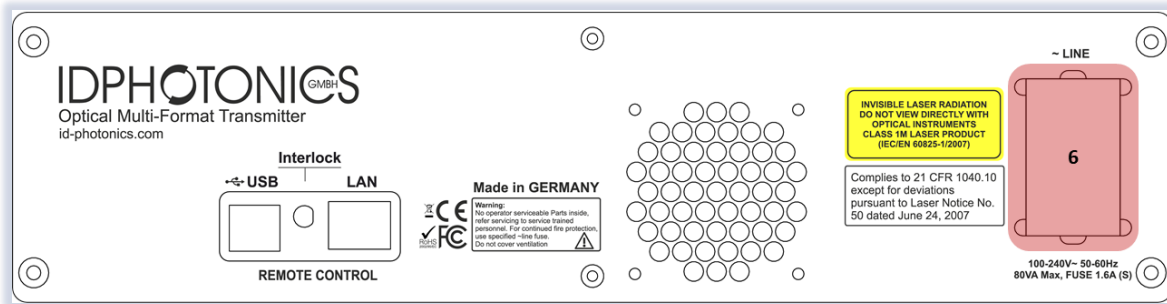

- Connect the optical input (2) of the Modulator to the laser output port (1) using the supplied PM Patch cord or an external laser source. Connect the modulator output to your setup (3)).

### OMFT CLASS 40 & 60

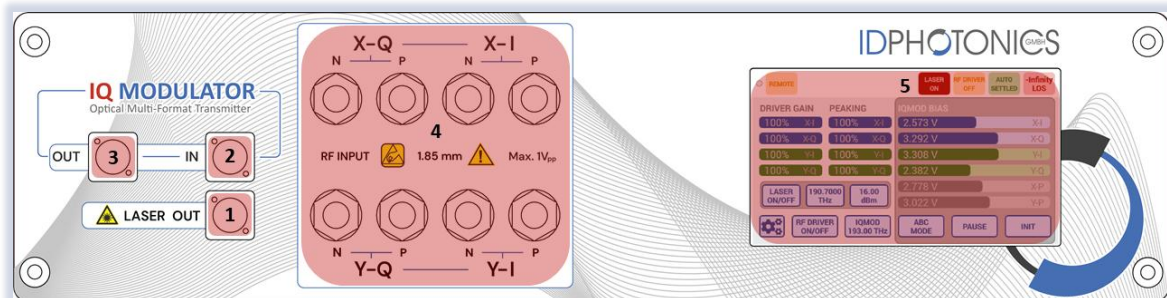

### OMFT CLASS 80

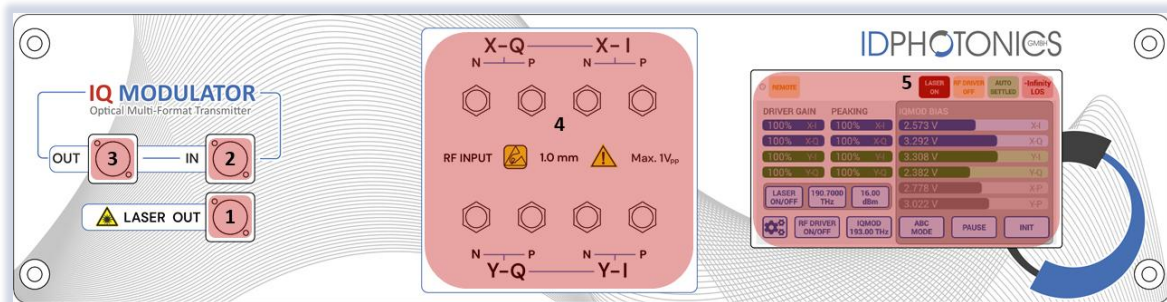

### ! NOTE

- Never exceed the maximum optical input power.
- Use only matching fiber connectors.
- Refer to inspection report for connector type installed in actual sample.
- Never open or close optical fiber connection when optical power is on.



- Never expose to laser radiation.
- Ensure clean fiber facets, when connecting.

**Make sure that the input polarization to the modulator is preserved by using PM Patch cords and a laser source with PM output.** Use the blue PM Jumper Fiber provided with the unit for this task.

- **Attach eight electrical RF cables to the RF inputs (4) and connect it to your RF electrical signal source (the RF signal source is not part of this product).**

**! NOTE**

- If you plan to drive the unit single ended, make sure to properly terminate the unused RF ports by suitable 50 Ohm RF terminators
- Make sure the RF signal source output is disabled
- Ensure proper skew-matched cables at the OMFT input plane.
- Never exceed the maximum RF input voltage swing.
- Turn-off the OMFT internal RF amplifiers as well as the external RF signal source when changing the electrical cabling.
- Use RF cables with matching connectors. Refer to inspection report for connector type installed in actual sample.

- **Switch on the OMFT** using the switch located at the rear panel next to the power socket (6)

**! NOTE**

Turn-off any optical amplifier subsequent to the OMFT in case:

- The OMFT is started or shut down
- The bias controller is reset or bias values are restored
- The electrical signal source is turned on or off
- The electrical signals are changed
- The optical input signals are changed or turned on/off

- **The unit will indicate its readiness in the local touch panel (5). The RF amplifier outputs and laser out are switched off by default.**
- **Set the IQMOD Frequency to the value set to same value as the laser source that is used.** If the internal laser is used, there is an option to automatically synchronize the settings.
- **Enable the laser source connected to the OMFT IQ Modulator setting 16 dBm as target power.** This is typically the internal laser of the unit. Make sure to never exceed a maximum total input power defined in the maximum ratings of the instrument. If the internal laser is used, set the desired frequency and power to the laser and enable the output by pressing the laser “Laser on” button on the local touch panel for about 2 seconds(5). Wait for the laser to finish tuning indicated by “Laser on” indicator.

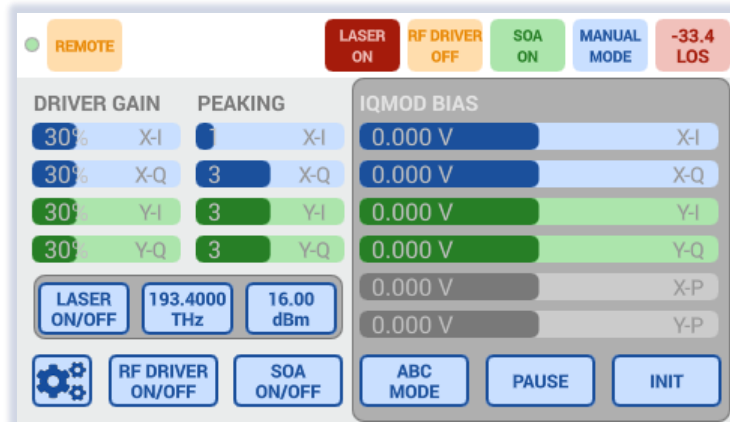

- Class 80 only: **Enable the SOAs** by pressing the SOA on/off button for 2 seconds.
- **Enable the Automatic BIAS Control (ABC)** by pressing the button “ABC MODE”. The ABC will start the optimization process indicated by a variation of the 6 displayed Voltages.
- **Setup the AWG RF Signal properly.** See Section 8.1 for some reference settings of a typical setup using a Keysight AWG.  
**Typical good settings are:** RF input swing  $V_{pp}$  differential = 250mV,  $V_{pp}$  single ended = 500mV, OMFT Driver Gain = 30% (Class 40) or 70% (Class 60), Peaking of 0% to 50%.  
 The unit does have calibrated default RF driver settings which are suitable to achieve good results for most applications.  
 Make sure to properly include the inter-channel skew of the OMFT into the waveform generation. The OMFT internal skew is implemented in the supplied S2P Files or can be found in the inspection report of the unit at hand. Both can also be retrieved from the Web GUI (Dropdown Files in upper right-hand corner) or by plugging in the USB connection which installs a Mass Storage device on the host PC (“USB Stick”).
- **Switch on the RF signal source connected to the OMFT (the RF signal source is not part of this product)**
- **Enable the OMFT internal RF drivers by pressing “RF driver on/off” for 2 seconds. The RF driver indicator should read “RF driver on” now.**  
 The LOS (Loss of signal) indicator in the touch panel should now deactivate to indicate that optical power is detected at the output of the Modulator. The ABC will continue to optimize its BIAS Point now.
- **Make sure that the Automatic BIAS Control is enabled by pressing “ABC Mode” to let the OMFT find the optimum operating point of the modulator. This process can take a few seconds up to 3 Minutes. The unit will indicate “ABC settled” once the process is complete**
  - The Voltages shown in the box “IQMod BIAS” should now be changing constantly, the factory default start values are close the optimal values already. Wait for “Auto Settled” indicator to become “green”. The voltages should now be changing in very small steps only.
  - Wait for about 60 seconds until the upper status indicator declares “ABC settled” or “ABC paused”. This is close to optimum but paused because the feedback signal is below -25dBm which is the Loss of Signal (LOS) threshold.
  - Validate that the ABC status indicator changed from “INIT” and then “Auto” to “Auto Settled” and “LOS Status” indicate “green” and “Alarm pending” indicator is off.

## ! NOTE

In Auto mode with no RF Power applied to the IQMOD (RF Amp off and/or RF signal source out off), the ABC will control to the transmission minimum causing the output power to drop below -25dBm or a “LOS” and “Auto Pause” since no modulation of the IQMOD is performed.

- The unit is ready now and the optical constellation can be detected.

## 2.1 REFERENCE VALUES

For a 32 GBaud/s PDM-QAM32 signal and a Laser source power of +16 dBm, the default gain settings of the RF drivers,  $V_{pp}$  differential = 250mV,  $V_{pp}$  single ended = 500mV for the RF signal source, the typical average output power of the OMFT should be in the range of -10 to -13dBm.

## 2.2 ACCESS OF WEBGUI

Connect the USB Port located at the rear of the unit to your Windows10 PC or connect the Ethernet Port to your LAN.

1. **For USB** based access, all drivers will be installed automatically, Windows device manager should show now 3 devices:
  1. A storage device containing manual etc.
  2. A virtual Ethernet Interface "RNDIS"
  3. A virtual COM PortBoth virtual COM and Ethernet Ports can be used to remote control the unit. The installed COM Port number can be retrieved from Windows device manager.  
To access the WebGUI, the USB virtual Ethernet IP address is needed. If the DNS configuration of your computer allows, the IP address can also be retrieved by entering the command shell "ping omft.local" or retrieve it from the label located on back of the unit. For a DX chassis, it can also be retrieved via the Touch panel under "Device Setup".
2. **For Ethernet** based access, the default IP of the unit is 192.168.0.1. Make sure that the host PC IP is in the same subnet as the laser unit (192.168.0.x). If this is not the case, you can change the IP settings of the unit via the touch screen or using the USB Port of the unit. Use <http://omft.local/> as an alternative to the IP address to connect to the unit if your DNS configuration of the network allows this access.
3. Open your Web browser, enter <http://omft.local/> or the IP address in the address field of the browser and hit <enter>. The Webpage allowing to control the laser remotely should open now.

**Note:** Depending on the configuration of your host PC DNS structure, the <http://omft.local/> name representation might not be resolved into the correct IP address. In such a case, for a DX unit, retrieve the IP Address on the local touch panel under "Device Config – Network Config" and use it instead of the name. For a DX2 unit, open a connection to the USB virtual serial interface and type the command "USBIPADDR?;" to retrieve the USB IP Address or "IPADDR?;" for the IP address of the Ethernet interface or retrieve the IP address from the type label located on the unit. Note that not all units have this information printed on.

## 3 OVERVIEW

The Optical Multi-Format Transmitter (OMFT) enables modulation of single or multiple optical carriers with various modulation formats, such as polarization-division multiplexed quaternary phase-shift keying (PDM-QPSK) or 16-ary quadrature amplitude modulation (PDM 16-QAM).

The block diagram below illustrates the overall architecture of the OMFT system and its signal flow between the optical, electrical, and control domains.

At the heart of the system is a tunable laser, which provides the optical carrier signal. This laser output is internally routed via a polarization-maintaining (PM) loop patch cord to the Optical IN port. From there, the signal passes through the Gain & Peaking stage, which includes the Semiconductor Optical Amplifiers (SOAs) and related circuitry that optimize the optical power level before modulation.

The optical signal then enters the modulator section, consisting of two Mach-Zehnder Modulators (MZMs) arranged in an I/Q configuration. This dual-modulator setup allows precise amplitude and phase modulation of the optical carrier for high-speed signal generation. Each MZM is managed by the system's Automatic Bias Control (ABC) circuit, which continuously monitors and adjusts the operating points to maintain optimal performance and signal quality.

The modulator section is implemented twice (x2), reflecting the system's capability for parallel or redundant modulation channels, depending on the selected configuration. The RF Input ports feed the electrical modulation signals into the MZM drivers, enabling the generation of advanced optical modulation formats.

After modulation, the optical signal is routed to the Optical OUT port, where it can be monitored on the Local Display or used for further optical processing or measurement.

All internal processes are supervised by the Control unit, which communicates with external systems via USB or Ethernet interfaces. These interfaces support multiple communication modes, including COM Port, Ethernet, and Mass Storage access.

User interaction is available through various interfaces:

- Web GUI (browser-based control)
- Terminal interface (command-line control)
- User software using SCPI commands

This architecture allows full remote control and monitoring of all system parameters, providing a flexible and powerful platform for high-speed optical signal generation and testing.

### 3.1 BLOCK DIAGRAM – CLASS 40G & 60G

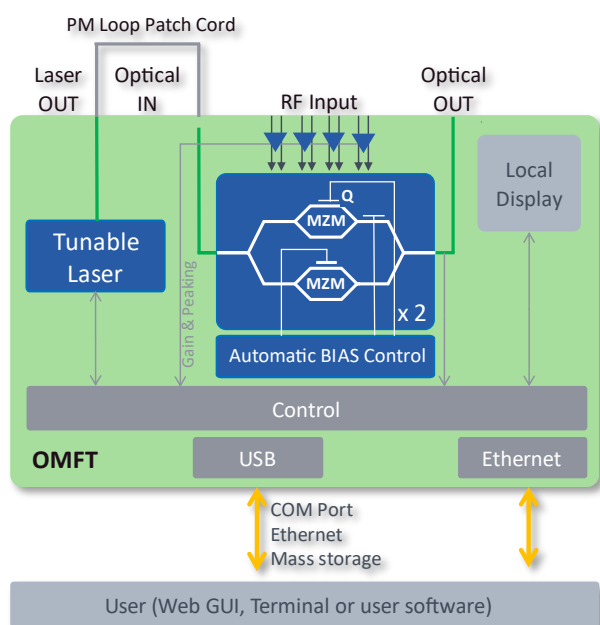

### 3.2 BLOCK DIAGRAM – CLASS 80G

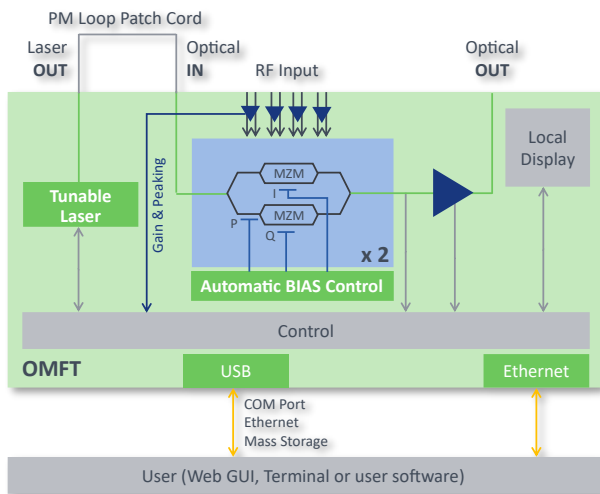

### 3.3 CLASS 80 ONLY - SOA OPERATIONS

The OMFT 80 is equipped with **Semiconductor Optical Amplifier (SOA)** block that functions as an integrated optical power amplifier. The SOA boosts the optical output power of the laser without converting the optical signal into an electrical one, allowing the system to achieve higher output levels and improved performance, especially for high-speed applications up to 80 Gbit/s.

The **SOA can be activated or deactivated in several ways:**

- By pressing the SOA on/off button in the Touch GUI,
- By using the corresponding control in the Web GUI, or
- Via the SOAONOFF SCPI command, which can be sent in the *SCPI Control* section of the Web GUI.

Note: User level 1 is required in the Web GUI to enable or disable the SOA. The Touch GUI is always authorized.

Internally, the OMFT 80 contains four SOAs, 2 for each polarization, one before and one after the MZM device. Depending on the operating state, the system's four SOAs (two pre-SOAs and two post-SOAs) can be in one of three states. These states are color-coded in the Web and Touch GUI as follows:

- **Gray:** all four SOAs are off
- **Orange:** both pre-SOAs are on, both post-SOAs are off
- **Green:** all four SOAs are on; only in this state is optical power emitted

The diagram below illustrates the operating states along with the corresponding color-coded SOA states:

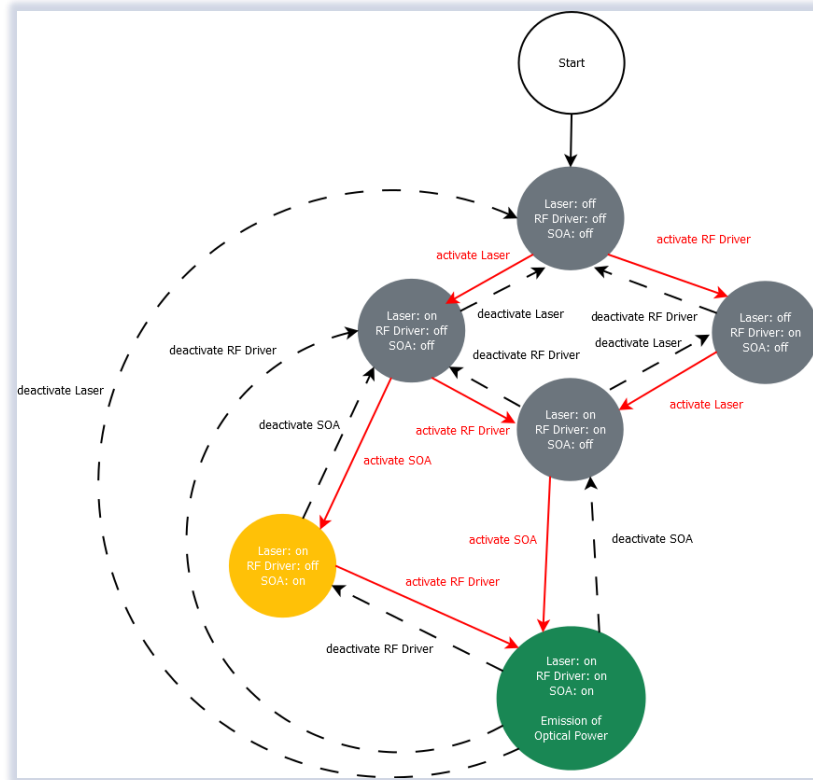

Compared to non-80G devices, 80G models feature four discrete peaking levels instead of a gradual increase, allowing for finer control of the output signal characteristics.

### 3.4 FUNCTIONAL BLOCK DIAGRAM

### 3.5 RF CHAIN

For that purpose, the OMFT amplifies four externally provided electrical drive signals (in-phase and quadrature drive signals for x- and y-polarization, respectively, generated by e. g. an arbitrary waveform generator or bit pattern generator) and subsequently converts them to the optical domain by means of an electro-optical dual-polarization in-phase and quadrature modulator (DP-IQ modulator). If the OMFT is equipped with an optional internal laser source, this source can be used to generate an optical carrier.

#### 3.5.1 RF DRIVERS

The unit features 4 differential RF inputs which are electrically amplified by internal RF amplifiers. Each amplifier channel can be individually optimized for RF gain and peaking. Peaking elevates the amplification if higher frequencies to achieve an overall flat frequency response since other components such as cables tend to exhibit a response that falls with frequency. Please refer to the inspection report of the unit at hand for details on the

frequency transfer curves.

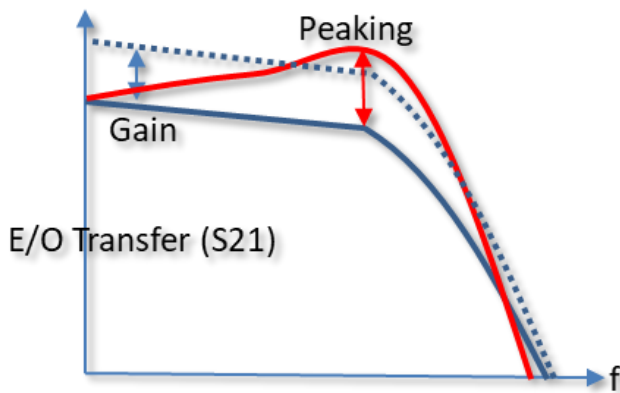

### 3.6 AUTOMATIC BIAS CONTROL

For turn-key operation of the OMFT, the modulator bias voltages are automatically controlled by an internal bias control device that sets and maintains the Optical IQ Modulator in an optimal operating point.

### 3.7 GENERAL

The instrument is operated via the local touch panel and an installation free Web interface operating in Web Browsers. Alternatively, a SCPI style command set can be used to operate the unit using a terminal window or third-party software.

The bandwidth and skew of the OMFT are characterized and provided to the user as calibration data. Hence, the user can fine compensate for the electrical skew and the bandwidths of the four electrical paths in case an arbitrary waveform generator (AWG) is used as a signal source by applying the corrections to the waveforms loaded in the AWG.

### 3.8 FRONT PANEL AND BACK PANEL VIEW

The front panel and back panel connectors are labelled and numbered as shown below. The following sections refer to this numbering.

#### 3.8.1 FRONT PANEL

##### OMFT CLASS 40 & 60

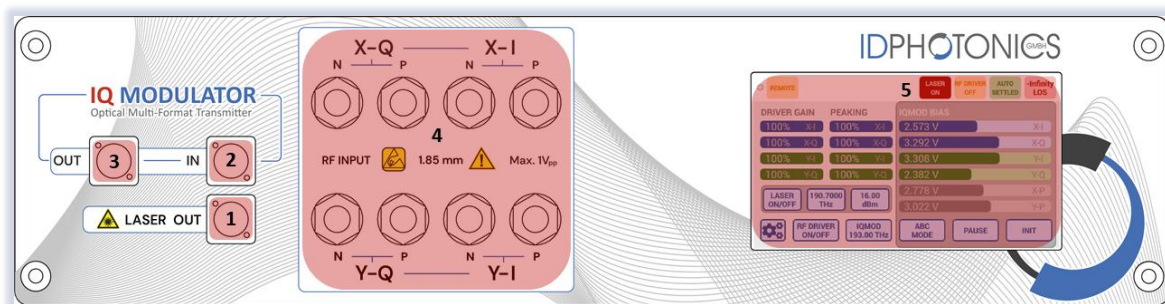

##### OMFT CLASS 80

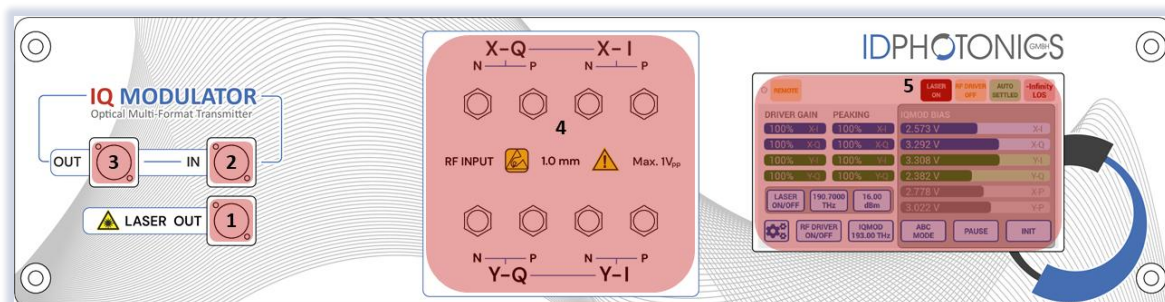

- (1) Optical laser output (optional) and status LED, indicating laser on/off state  
Refer to inspection report for connector type installed in actual sample.
- (2) Optical modulator input  
Refer to inspection report for connector type installed in actual sample.
- (3) Optical modulator output  
Refer to inspection report for connector type installed in actual sample.
- (4) Electrical RF inputs  
Refer to inspection report for present configuration in your sample.
- (5) Touch Panel  
Local control and status information on the unit

### 3.8.2 BACK PANEL

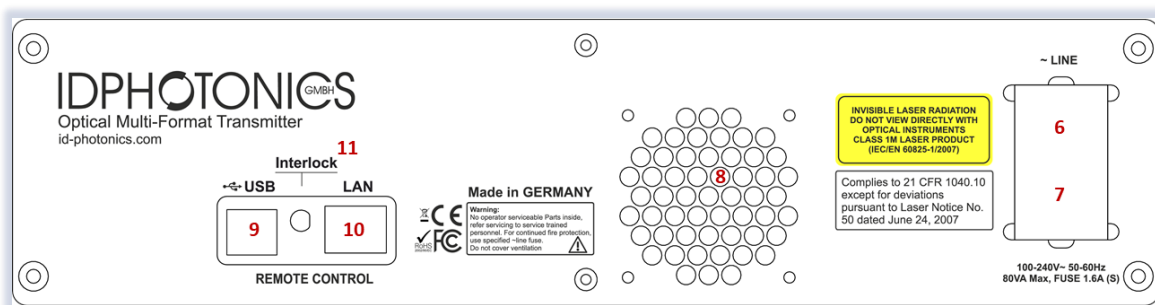

- (6) Power cord socket, On/off switch  
100 to 240 V, 50 to 60 Hz
- (7) Main fuse compartment  
one piece, 100 VA, 4A, slow
- (8) Fan outlets  
do not cover!
- (9) USB port  
USB-A female, for remote control
- (10) LAN port  
RJ45, port for remote control
- (11) Interlock  
Will disable Laser Output by Hardware for units with laser equipped

### 3.9 MACH ZEHNDER MODULATOR - THEORY OF OPERATION

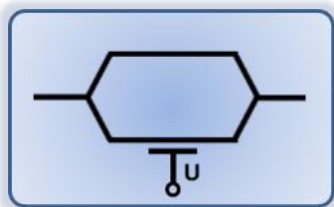

Mach-Zehnder modulator structures are a popular way of modifying the intensity or phase of light waves that are based on a Mach Zehnder interferometric setup. The light is split, guided in 2 distinct paths and combined again to achieve interference. Utilizing materials with a strong electro optical effect allow changing the relative phase of the optical carrier waves that are converted into intensity changes by means of interference at the output achieving a modulation of the light.

The power transfer curve of a single MZM as a function of applied voltage is shown below.

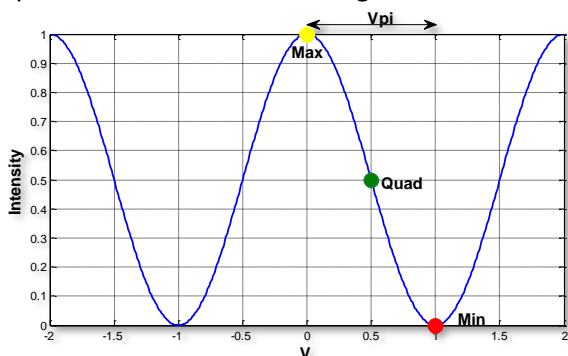

The Voltage change required to change the output power from maximum to minimum or vice versa is defined as  $V_{\pi}$  ( $V\pi$ ). The mid-point between maximum and minimum transmission is defined as Quadrature (Quad). The unit at hand provides 2 nested Mach-Zehnder structures as depicted below. Each structure contains 2 inner Mach-Zehnders for I&Q modulation (XI, XQ for X Polarization and YI, YQ for Y Polarization) which are nested in an outer Mach-Zehnder structure that shifts the optical phase between the two inner Mach-Zehnders (XP and YP respectively).

The functional diagram below shows the configuration for the dual Pol IQ Modulator setup used in this instrument consisting of a Super MZM structure of 2 nested MZMs used for I and Q modulation. The incoming single polarization signal from a laser source is split into 2 parts and the polarization of 1 part is rotated orthogonally before routing them through 2 parallel of structures X and Y Polarization each handling 1 Polarization

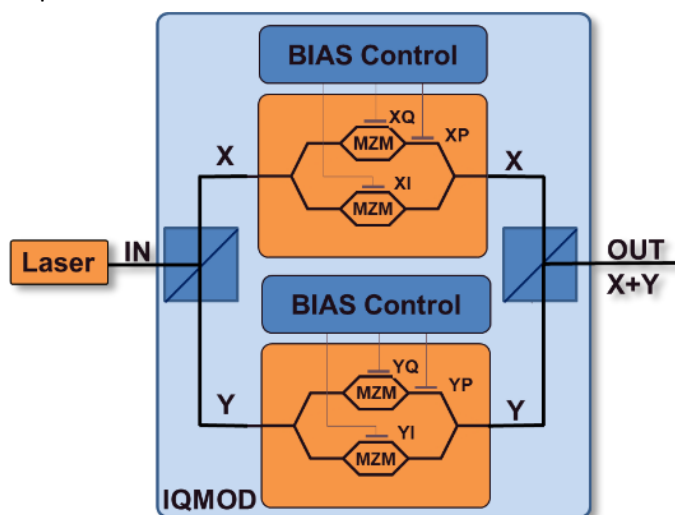

#### 3.9.1 AUTOMATED BIAS CONTROL

The Automated BIAS Control feature of this unit is used to set the BIAS Voltage of Mach Zehnder Modulators (MZM) to its optimal operating point over carrier frequency, temperature and time by means of dither tones imposed onto the BIAS Electrodes and feedback signals generated from a photodiode monitor tap located after the MZM elements.

A key feature is the independence of the applied modulation format for IQ Modulator control supporting advanced modulation formats such as Nyquist shaped signals, QAM, SSB and pre-distorted signals. Furthermore, a BIAS optimization is possible without a RF signal present.

The control loop utilizes feedback signals derived from a feedback photodiode located after the MZM structure by means of dither tones that are applied to the BIAS electrodes of the MZM.

## 4 HARDWARE SETUP

This section describes the step-by-step procedure to connect the OMFT to external hardware and to put the OMFT device into operation.

### 4.1 GROUND THE INSTRUMENT

To ensure proper grounding of the OMFT device, connect the electrical power cord to the power cord socket (6).

#### ! NOTE

Do not turn-on the OMFT before the steps 4.2 to 4.6 are properly performed.

### 4.2 LAN OR USB CABLE FOR REMOTE CONTROL

The user can use both USB and Ethernet as interface for remote control of the OMFT with the provided GUI or using SCPI commands from self-built software.

#### 4.2.1 ETHERNET CONNECTION

This section covers connectivity using Ethernet, skip it if you plan on using USB.

The default IP address is 192.168.0.1, DHCP off. If you plan to connect using the Ethernet interface, make sure the host PC is within the same subnet as the OMFT Ethernet Interface (The PC IP Address is 192.168.0.x then). The connectivity can be tested by opening a command shell (type “cmd” in windows search field and hit <enter>, a “black window with a DOS shell should open) and executing the command “ping 192.168.0.1”.

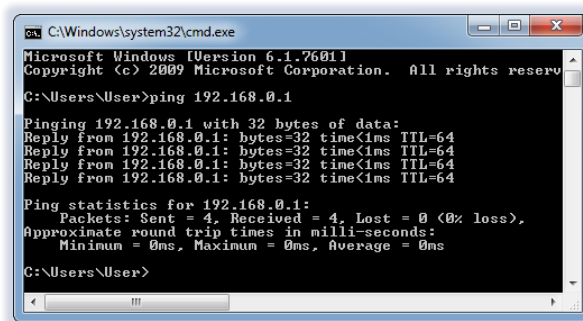

```

C:\Windows\system32\cmd.exe
Microsoft Windows [Version 6.1.7601]
Copyright (c) 2009 Microsoft Corporation. All rights reserved.

C:\Users\User>ping 192.168.0.1

Pinging 192.168.0.1 with 32 bytes of data:
Reply from 192.168.0.1: bytes=32 time<1ms TTL=64
Reply from 192.168.0.1: bytes=32 time<1ms TTL=64
Reply from 192.168.0.1: bytes=32 time<1ms TTL=64
Reply from 192.168.0.1: bytes=32 time<1ms TTL=64

Ping statistics for 192.168.0.1:
    Packets: Sent = 4, Received = 4, Lost = 0 (0% loss),
    Approximate round trip times in milli-seconds:
        Minimum = 0ms, Maximum = 0ms, Average = 0ms

C:\Users\User>

```

#### 4.2.1.1 CHANGE OF IP SETTINGS WITH REMOTE ACCESS

If you do wish to change the IP settings and do not have remote access to the unit, use the local touch panel and press device Setup (Gear symbol). Then press “Network setup” and configure the interface accordingly.

Alternatively, use the WebGUI or the SCPI interface to change the settings. Note that this change will require a reboot (soft reset of the unit) to become effective.

Note that changing the IP address requires the user to be connected with user level 1 or higher. Send the command “pass IDP” or enter the password “IDP” in the GUI to elevate the user level to 1.

#### 4.2.2 OPENING A REMOTE CONNECTION VIA ETHERNET

The device supports a session based remote access on Port #2000.

Start the terminal program “putty.exe” supplied with the unit or use any other terminal program.

Set the following parameters in PuTTY and open the connection:

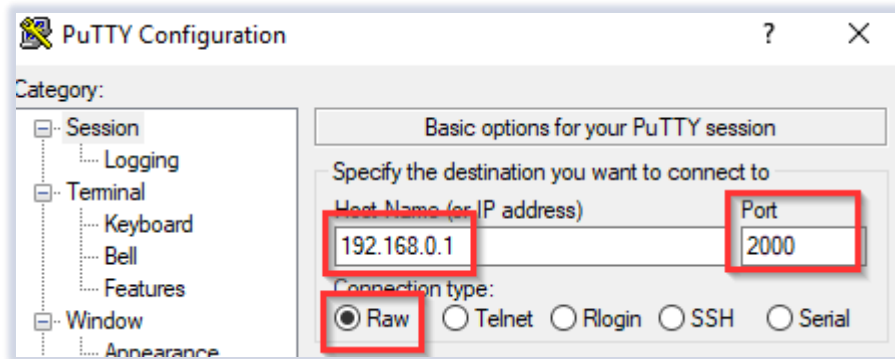

Alternatively to the default IP Address shown above, enter “omft.local” or the IP address currently set to the unit. If in doubt, use the touch panel display “Device config” – “IP config” to retrieve the actual IP Address. Note that there must be a valid route on the IP layer between the device and the host PC (i. e. the ethernet port of the host PC is set to the same subnet as the device, for example 192.168.0.2) must be established before continuing. Use a command shell and command “ping omft.local” to test the route. Once the connection is established, type in “\*idn?” and hit <ENTER>. The unit responds with its \*idn? String.

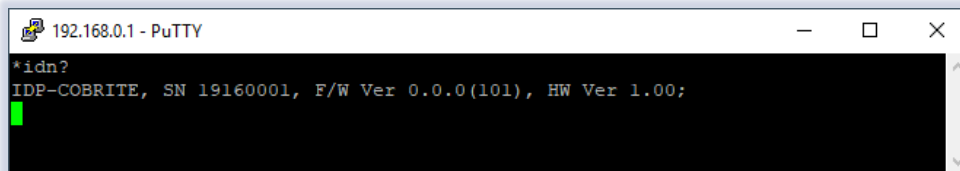

Alternatively, a request based remote control via http Port 80 is possible. To test this, open a browser window and type the following string into the address field:

[http://omft.local/scpi/\\*idn?](http://omft.local/scpi/*idn?)

For more details, see section 7.2 and section 4.2.

### 4.2.3 USB CONNECTION

This section covers connectivity using USB, skip it if you plan using Ethernet.

Once the unit is powered up and the USB cable is connected to the host computer for the first time, a new device installation should be triggered automatically within Windows.

Once installation is complete, three devices are installed on the host computer:

1. Virtual Ethernet Interface
2. Virtual COM Port
3. Virtual Storage device that contains resources such as manual and programming devices as well as drivers for Windows 7. It also contains the S2P Files as well as the inspection report of the unit.

#### 4.2.3.1 WINDOWS 10

Windows 10 will automatically install 3 devices allowing to connect the unit

1. A virtual Ethernet interface (RNDIS)
2. A generic virtual COM port driver “Serial USB device”. If you have several COM ports installed in the host PC, you may want to note the COM Port number under which the unit got installed. For further details on USB connection, see section 4.2.3.3.
3. A storage device similar to an USB Stick containing resources for the laser unit

The virtual COM Port and the virtual Ethernet interface are concurrent ways to access the unit for remote control. The web-based control is automatically accessed via entering “omft.local” or 192.168.0.1 (if default is set) into your browser.

#### 4.2.3.2 WINDOWS 7

Windows 7 will install the same structure as described in the windows 10 section above. It will automatically install a virtual Ethernet interface (RNDIS) and the USB storage device (“Linux File- Store Gadget USB Device”). However, it does not have a preconfigured driver setup for the virtual COM Port. It will try to locate a driver for the unit on the host PC first and then check online. Stop the search and select the option “Install a custom driver”. Point the installation routine to the driver located on the USB storage device provided by the unit in directory “USBDriverWin7” and select file “OMFTUSBSerialDriverWindows7.inf” in this folder. If the installation has been completed already, open Windows Device Manager, locate “CDC Serial”, right click on it and select “Update driver”. Proceed as described before.

Continue with the installation routine. Once installed, the virtual COM port should appear in Windows Device Manager as shown below. The COM Port number will be different for your system. Note down the number for later usage in remote control applications.

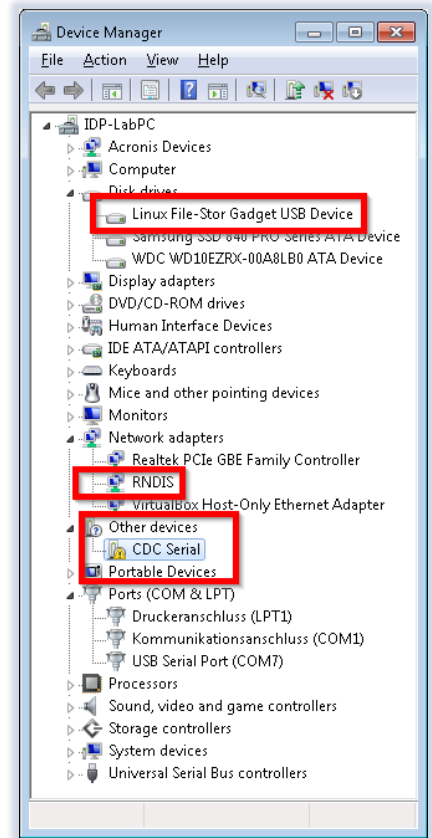
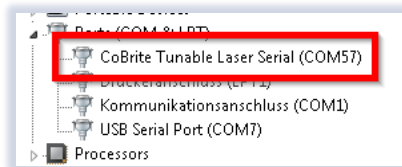

#### 4.2.3.3 CONNECTION TO THE DEVICE VIA USB VIA HOST PC

Once installed properly, the USB connection provides a virtual COM Port and a virtual Ethernet Port to the instrument. To access the unit via virtual Ethernet, follow the instructions as in section 4.2.2 but note that the IP Address of the unit will be different as for the physical Ethernet Port.

To access to the unit using the virtual COM port, open a terminal window using the installed COM port number per description above.

#### 4.3 INSTALLATION OF CONTROL SOFTWARE

This instrument does not require any installation of software for operation. Once connected to a host PC or a local network, simply enter “omft.local” into the address field of your Web browser to access the unit. For more details, see section 7.2 and section 4.2.

#### 4.4 LASER OUTPUT (OPTIONAL, DEPENDING ON DEVICE CONFIGURATION)

Before connecting or disconnecting the optical fibers to the OMFT, it is strongly recommended to turn-off the laser sources any time! Never directly expose yourself or others to laser radiation! Permanent eye damage may occur!

The laser output port (1) is an optional feature to the OMFT unit. The internal laser source provides a narrow line width tunable source suitable for coherent transmission. A virtual red status LED in the touch panel GUI indicates the laser on/off state.

In case an internal laser is installed, the laser output (1) may be connected to the optical modulator input (2) using the supplied blue PM jumper patch cord. Use the local touch panel or remote control to enable and configure the laser (refer to Section 0 for further instructions).

#### 4.5 OPTICAL MODULATOR INPUT AND OPTICAL MODULATOR OUTPUT

Before connecting or disconnecting the optical fibers to the OMFT, it is strongly recommended to turn-off the laser sources any time! Never directly expose yourself or others to laser radiation! Permanent eye damage may occur!

Connect a laser source (or sources) to the optical modulator input of the OMFT (2) using the appropriate connector cable. Refer to inspection report for connector type installed in actual sample. The laser source can either be the optional internal laser, if it is installed, or an external laser source. If the optical modulator input of the OMFT is PM, ensure that the laser source (or sources) has PM outputs.

Connect the optical modulator output of the OMFT (3) to the user's measurement equipment, e.g. a coherent receiver, using an appropriate connector cable. Refer to inspection report for connector type installed in actual sample.

### NOTE

Clean the fiber connectors each time they are connected to the OMFT device. Dirty connectors will increase the optical losses and/or possibly damage the connector! Dirt or pollution may also lead to damage of the fiber facets inside the OMFT.

### NOTE

Do not turn-on any laser source(s) connected to the optical modulator input of the OMFT, before the OMFT is started. Start-up of the OMFT device resets the bias values to default values, resulting in fast changes of the modulator output signal intensity or loss of the modulator output signal. These fast changes in combination with optical amplifiers such as EDFAs (Erbium-doped fiber amplifiers) might cause optical transients or surges which can damage any equipment connected to the optical modulator output of the OMFT.

### NOTE

Never exceed the absolute maximum ratings for the optical modulator input power (refer to section 0).

## 4.6 CONNECT THE RF INPUTS

### NOTE

Avoid any electrostatic discharge, which may harm the RF devices inside!

Turn-off the electrical RF-amplifiers (RF Driver indicator in Touch panel must be OFF) as well as any signal source's electrical outputs connected to the OMFT, each time the cables are connected or disconnected.

Connect the electrical signal source (e. g. bit pattern generator or arbitrary waveform generator) to the electrical inputs of the OMFT device (4) by means of high-quality electrical cables (i. e. high bandwidth, high phase stability) mechanically matching the electrical input connectors of the OMFT. Refer to inspection report for connector type installed in actual sample.

The user should ensure properly de-skewed electrical signals at the OMFT input plane. The remaining skew of the electrical paths inside the OMFT can be compensated either by software in combination with an arbitrary waveform generator or by mechanical phase shifters (see Appendix 8.2.3 De-skewing of RF Drive ).

The output of the electrical signal source providing the electrical input signals to the OMFT can be turn-on after connection of the cables.

### NOTE

Never exceed the specified maximum electrical peak-to-peak amplitude to the OMFT (refer to section 0).

It is recommended to use a torque wrench with defined torque (e. g. 0.90 Nm for 1.85mm type - connectors) to tighten the nuts of the cable and connectors. Excessive torque will damage the cable and/or the connectors on the unit!

The unit utilizes differential RF inputs for optimum performance. However, the unit can be operated in single-ended configuration as well. In this case, terminate the unused input with proper 50Ohm terminators.

## 4.7 SWITCH ON THE OMFT DEVICE

After steps 4.1 to 4.6 are performed, the OMFT can be started by pressing the main power-on switch located at the rear panel of the unit. Wait for approximately 1 minute until the OMFT device has booted and ready which is indicated on the touch panel display.

Now, the external optical signal sources or the internal laser (optional) connected to the optical modulator input of the OMFT can be switched on.

### ! NOTE

Make sure that the total optical input power level to the OMFT does not exceed the specifications given in section 0 and that no fiber connector is open or dirty.

Start-up of the OMFT device resets the bias values to default values, resulting in fast changes of the optical modulator output signal intensity or loss of the optical modulator output signal. These fast changes in combination with optical amplifiers such as EDFAs (Erbium-doped fiber amplifiers) might cause optical transients or surges which can damage any equipment connected to the optical output path of the OMFT.

### ! NOTE

Turn-off any optical amplifier subsequent to the OMFT in case

- The electrical signal source is turned on or off
- The electrical signals to the OMFT are changed
- The optical input signals are changed or turned on/off
- Or the bias controller is reset or bias values are restored

## 5 TUNABLE LASER

This section only applies to units with a built-in tunable Laser source.

The integrated tunable Laser provides a grid-less step tuning mode (Coarse tuning) with a feature to detune the frequency set by Coarse tuning with higher resolution (Fine tuning).

### 5.1 LASER TUNING MODES

Coarse tuning allows accessing the full specified tuning range while fine tuning (FTF) allows for offsetting from the coarse tuning set point by a small range. The resulting set point is the sum of coarse tuning set point and FTF/fine tuning value.

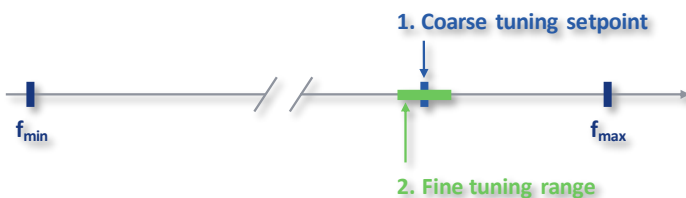

### 5.2 COARSE TUNING

This tuning mode allows tuning the laser to any frequency of the available range specified for the laser port. The tuning process will require the laser output to be disabled for a short period of time.

Description of tuning process:

1. Laser output will be switched off (~1 second)
2. Laser output is switched on using new frequency
3. Power is increased until final laser output power is reached. Maximum tuning time for this step is 15seconds

4. Power is stabilized, tuning process is completed.

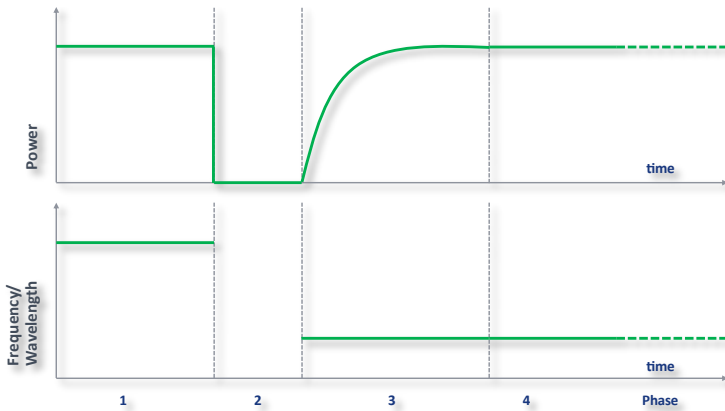

### 5.3 FINE TUNING (FTF)

Fine tuning allows detuning the laser within a small range of a few GHz from the target frequency that was set using the coarse tuning parameter. The laser will detune to the target setting with laser output power on during the tuning process which changes the output frequency in a linear ramp. Tuning target setting resolution is 1MHz.

1. Tuning is triggered
2. Tuning process is executed with a rate of  $\sim 0.11$  GHz per second. During the process, the Laser output power remains constant.
3. Laser settles on new value

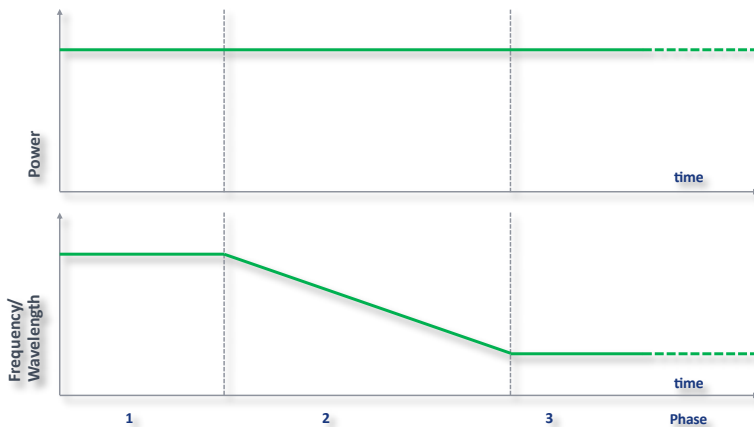

## 6 USER INTERFACES – TOUCH PANEL AND WEB INTERFACE (WEBGUI)

### 6.1 LOCAL TOUCH PANEL BASED USER INTERFACE (TOUCH GUI)

#### 6.1.1 MAIN SCREEN

This Screen is partitioned into several areas controlling the building blocks of the unit (See also section - for details of the building blocks).

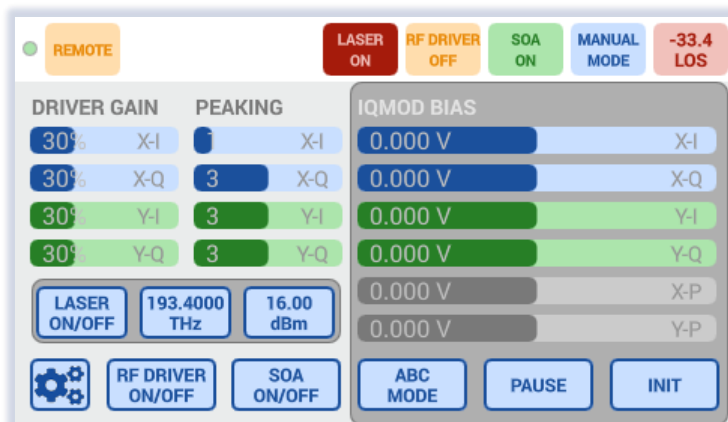

- The **top bar** is used for indicators that inform about the status of the unit
  - **Green/grey dot:** The dot is slowly blinking to indicate the application is ready and polling data
  - **Remote:** A remote session via Ethernet or USB is currently active
  - **Alarm** (not displayed): If any Alarm is pending, the indicator is showing up. Tick the indicator the retrieve more detailed information on the alarm
  - **Interlock** (not displayed): Indicates that the hardware safety interlock located at the rear of the unit is currently active. A built-in laser cannot be enabled if Interlock is active. The interlock jumper is located at the rear panel of the device.
  - **Laser on/off/tuning** (units with internal laser): Indicates the output status of the built-in tunable laser.
  - **RF Driver on/off** Indicates the output status of the RF Drivers for the IQ Mod Component.
  - **SOA on/off** (only displayed for 80G devices) Provides information on whether the SOA is on or off
  - **BIAS Control Status** This indicates the status of the IQ MOD BIAS Control. It can assume the states: {Manual/Init/Auto/Auto Settled/ABC Paused}. See details in section 6.5).
  - **Power Indicator** The optical output power of the unit is monitored by a tap Photodiode. The output power is indicated here. In case the signal power drops below the Loss of Signal Threshold (LOS) the indicator color is turned to red and LOS is declared. This will halt the IQ MOD BIAS Control (Auto Pause).
- Driver Gain and Peaking** indicate the current setting of the RF channels and allows controlling the gain level and the spectral peaking setting by a touch on the corresponding bar. This will open up a pop up with a slider of which the setting is immediately transferred to the hardware.

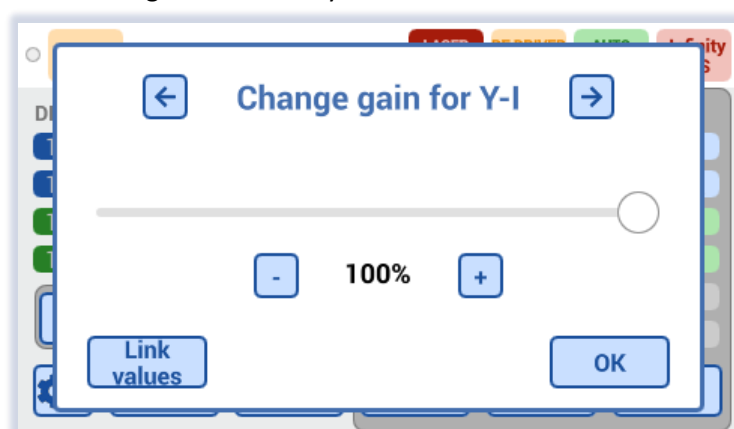

“Link Values” will apply the same setting of the current channel to all other channels. Click on the upper arrows to access the other channels. Press ok to close the pop up.

3. **Laser** (only on units with built-in laser): Press and hold the Laser on/off button to enable or disable the laser. The buttons indicate the status of the lasers and allow to change the setting by clicking on the buttons. This will open a popup that allow to change the laser settings. “Synch IQMOD” will set the same Frequency/Wavelength setting dialed in for the laser to the IQ Modulator. Changes will be applied when the ok button is pressed.

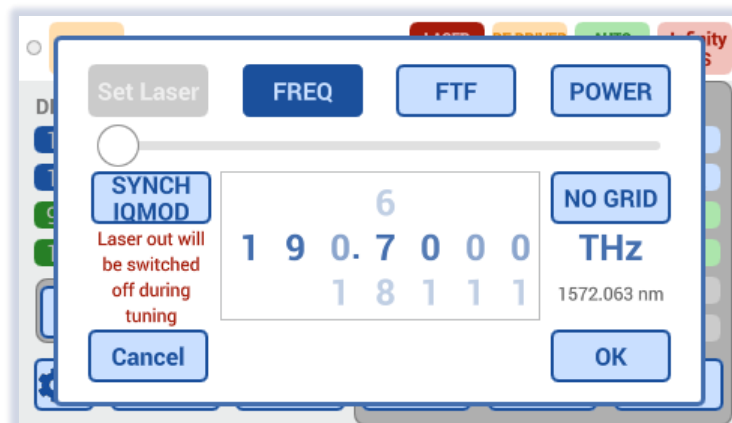

4. **RF Driver on/off** Press and hold the RF driver on/off button to enable or disable the RF channels. Make sure that the RF Inputs are properly connected before the RF Amplifiers are enabled. Note that there are optical transients may occur when the RF amplifiers are enabled and an RF Input signal is present. Make sure to protect the downstream setup like Photodiodes accordingly.
5. **SOA on/off** (only displayed for 80G devices) Press and hold the SOA on/off button to activate or deactivate the SOA. Note that the laser must be switched on to activate the SOA.
6. **IQMOD Frequency** indicates the current frequency setting of the IQMOD and allows controlling the setting by touching on it. Always set this value to the Carrier Frequency of the connected laser source to ensure optimal performance of the device.
7. **IQMOD BIAS** Indicates the current settings of the BIAS Voltages. See section for details 0. In Auto Mode, these values are automatically optimized. In Manual mode, the values can be changed by touching any of the bars. This will open up a pop up allowing to change the setting. This will be applied immediately upon input. Use the arrows to cycle to the next electrode. Press ok to close the pop up.

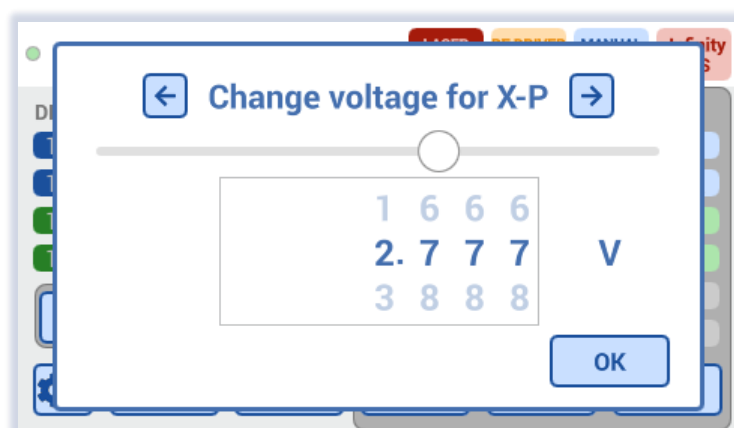

8. **ABC Mode** Press this button to toggle the Automatic BIAS Control (ABC) for the IQMOD between Auto Mode and Manual Mode. The current status is indicated in the status bar at the top. In Manual mode, the BIAS Values can be changed by the user. When switched from Manual to Auto, the settled status is cleared and reacquired. For short stops of the ABC, use the Pause/Mute mode instead.
9. **Pause** halts the ABC in the current setting. This can be used to take measurements without the interference of the working ABC. Toggle again to restart the ABC. In contrast to switching into manual mode, the ABC will immediately halt even if an active ABC cycle is performed and does not re-acquire the settled status when resumed.

10. **Init** Will Initialize the ABC to its startup status. Note that there are optical transients may occur when Init is performed. So, make sure to protect your setup like Photodiodes accordingly.
11. **Setup** (Gears) allows to show and change system settings of the unit. See next section for details.

### 6.1.2 SETUP SCREEN

Pressing the “Gear” button in main screen opens a popup to access the setting of the unit.

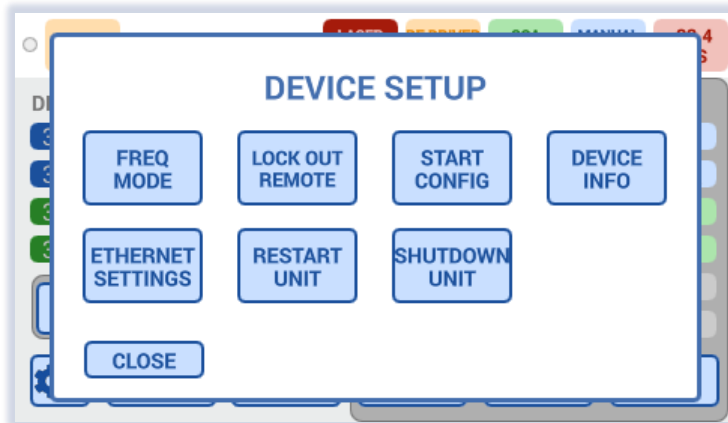

**Frequency/Wavelength Mode** allows toggling between system wide display of carrier wavelength or frequency.  
**Lock Out Remote** will close current remote sessions to the device and reject future requests as long as this mode is active-  
**Start Config** enables the user to set the configuration for the next reboot. It can be chosen between the last save configuration or the factory defaults. Also the user can en- or disable the autostart of the laser.

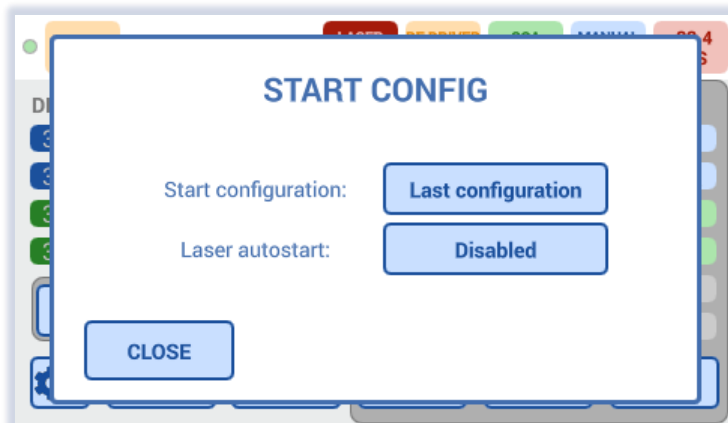

**Device Info** provides Device configuration, software and hardware version and serial number information  
**Ethernet Settings** provides access to the settings of the physical and virtual Ethernet interface of the unit. Touch the corresponding buttons to change the settings. Changes to the settings become effective only after a reboot of the unit.

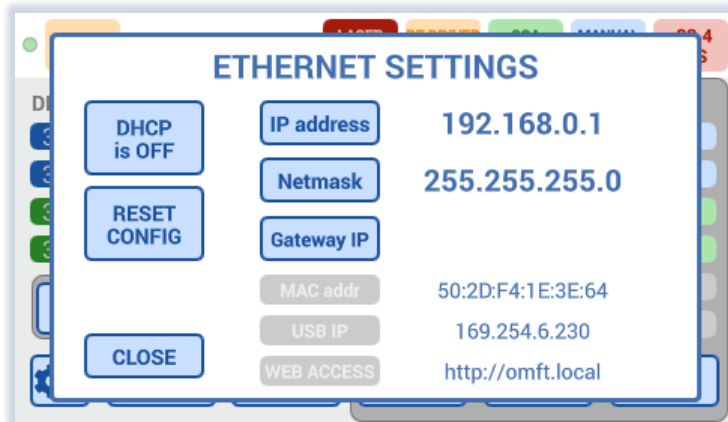

**Restart unit** will perform a soft reset of the unit.

**Shutdown unit** Will safely shut down the hardware and software of the unit. Always perform this step before switching off the unit using the main power switch.

## 6.2 WEB BASED GRAPHICAL USER INTERFACE (WEBGUI)

The WebGUI can be accessed from any host device such as a PC that is either on the same Ethernet Network as the OMFT unit or is connected via Ethernet and supports the USB virtual Ethernet structure (i.e. Windows 10 devices).

The WebGUI can be accessed by entering “omft.local” into the address field of the internet browser. The WebGUI was tested with Edge, Chrome and Firefox with current revisions at the time of testing.

### 6.3 WHAT IF “OMFT.LOCAL” CANNOT BE REACHED BY HOST COMPUTER?

Depending on the configuration of your host PC DNS structure, the <http://omft.local/> address might not be resolved into the correct IP address of the device.

In case the name resolution is not working in your network, open the device settings on the local touch panel to retrieve the IP address of the unit. Enter the IP address in the address field of the browser instead.

#### 6.3.1 IP ADDRESS RETRIEVAL - LOCAL TOUCH GUI

Retrieve the IP Address in local Touch display under “Device Config – Network Config” and use it instead of the name.

Note that there are 2 IP addresses shown, one for the physical Ethernet interface (Network Interface) and one for the virtual Ethernet interface installed via USB.

#### 6.3.2 ETHERNET METHOD

If the default IP address of the device was not altered, it is “192.168.0.1”. Configure the Ethernet address of the host PC to 192.168.0.2. Make sure to disable to disconnect other Ethernet interfaces on this PC to avoid potential interference. Connect the Ethernet cable to the host PC and the unit. LEDs next to the Ethernet should become green. Enter “192.168.0.1” into your Browser on the Host PC.

#### 6.3.3 LABEL

There is a label showing the serial number and part number located at the back of the unit that has the default IP Address for both Ethernet IP and USB IP.

## 6.4 DESCRIPTION OF WEBGUI

The WebGUI was tested on Windows 7, Windows 10 and Windows 11 Computers using Edge, Chrome and Firefox and iPhone/iPad using Safari browser. Note that we cannot guarantee operation in any Browser environment in general.

The WebGUI functionality is very similar to the local touch interface. A short overview is given here. For details, see the local Touch WebGUI description.

### 6.4.1 HEADER BAR

On its right side, the header bar contains status indicators such as the current output power, alarm status, device mode etc., as well as the device's IDN string, which includes information such as the serial number and firmware version. Furthermore, the user has the option to log into the device. Note that the SOA ON/OFF status indicator is only visible for Class 80G devices.

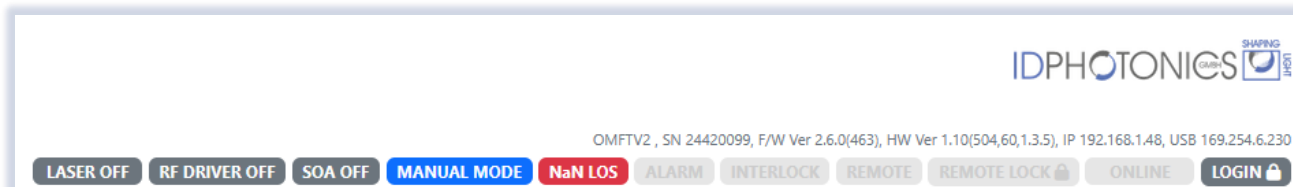

On the header bar's left side, the user can open the main menu by clicking the burger menu icon. This menu allows the user to access resources such as the user manual related to the unit. These resources are stored locally on the device. In addition, the user can update the firmware and restart the unit from this menu.

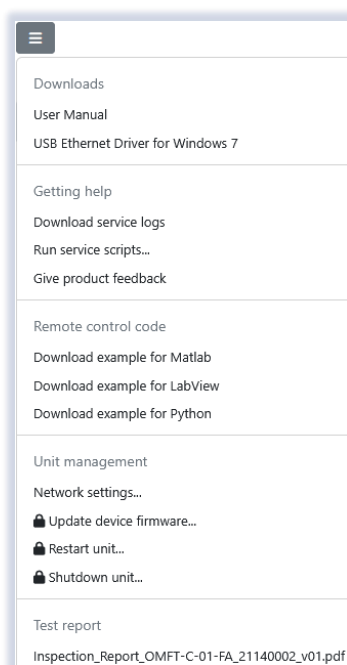

### 6.4.2 RF DRIVER/IQMOD BIAS TAB

This tab allows accessing most of the device features for daily usage. It is essentially divided into three sections.

The top section enables the user to interact with the ABC. The user can change the DRIVER GAIN, PEAKING and IQMOD BIAS values by clicking the corresponding bars and entering the new values in the popup window that appears. Changing the IQMOD BIAS values requires manual mode.

In the case of a Class 80G device, the user has the option to activate the SOA here by clicking the corresponding button. Changing the SOA status requires user level 1.

**Note:** the laser must be switched on before the SOA can be enabled. Unlike non-80G devices, 80G devices feature four peaking levels instead of a gradual increase.

The following provides a more detailed description of the components in this section.

- **Driver Gain:** these controls set the RF driver gain of the integrated RF amps.
- **Peaking:** these controls set the RF driver peaking of the integrated RF amps
- **IQMOD Bias:** these controls display the BIAS of the MZM structure control

- **Buttons**

- RF Driver On/Off: En- or disables the RF driver output
- SOA On/Off (only displayed in the case of a Class 80G device): Activate/Deactivate SOA
- IQMOD x: Sets the current frequency/wavelength for the IQMOD to x THz/nm in order to optimize its performance
- ABC Mode: changes the ABC status between automatic mode and manual mode
- Pause: pauses the automatic mode of the ABC
- Init: Initializes the ABC which will change the current BIAS setting and therefore may cause sudden optical output power changes of the MZM structure

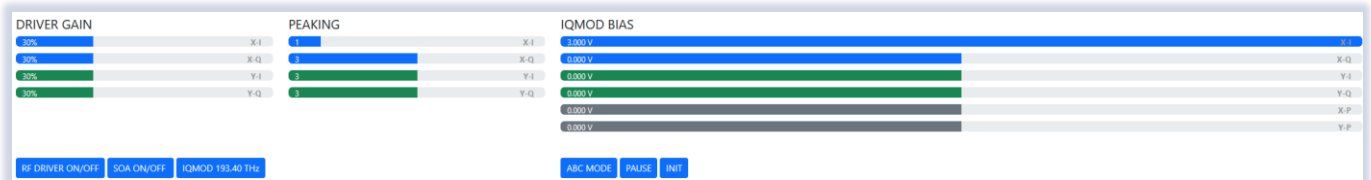

Independent of the device type, the second section always contains a graph which visualizes the IQMOD BIAS values in Volt. The legend on the graphs to right corner shows which graph corresponds to which channel.

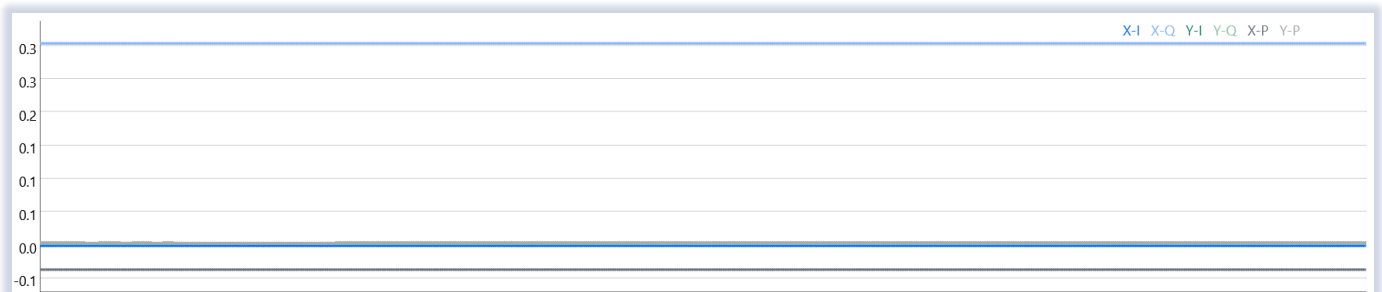

If the OMFT contains a laser, the third section enables the user to modify the laser settings. To change a setting, the user must click a parameter and enter a new value, which is applied either by clicking the check mark or pressing <enter> on a keyboard. Each setting is applied separately.

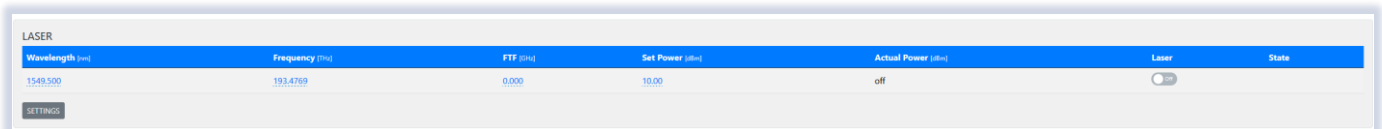

Alternatively, the user can modify all laser settings at once by clicking the *Settings* button and entering the new values in the popup window that appears. This window also allows the user to sync the IQMOD Calibration carrier frequency to the current setting of the laser.

**Laser settings** ✕

Port  
1-1-1

Wavelength (1524.498 .. 1572.063 nm)  
1549.500

Frequency (190.7000 .. 196.6500 THz)  
193.4769

Automatic Sync IQMOD to Laser Frequency/Wavelength

FTF (+/-6.000 GHz)  
0.000

Set Power (10.00 .. 16.02 dBm)  
10.00

Laser on/off status  
**LASER OFF**

Note, laser out will be switched off during tuning if frequency parameter is changed.

Set changes
Discard & close

### 6.4.3 SYSTEM TAB

This tab displays the current unit configuration number, which increments each time the unit configuration is changed. In addition, the user can store all system settings to a file or, conversely, restore system settings from a file. Restoring system settings from a file requires manual mode. The user also has the option to reset all user settings to factory defaults.

### 6.4.4 SCPI CONTROL TAB

This tab enables the user to communicate with the device via SCPI. The responses will be displayed in a popup window. Also, the user has the option to log the SCPI commands used and their responses. Note that some SCPI commands require user level 1.

For more detailed information about SCPI commands, please refer to chapter *section* General SCPI Commands and the following sections.

**Start configuration**

Start with last configuration

Laser autostart disabled

**Settings storage**

Config ID  
37

Save configuration to file

Restore configuration from file

Reset all user settings

**SCPI control**

Send command:  
partno?

**Communication log**

Log events:  
 SCPI commands     SCPI replies

---

```
*!dn?
>> OMFTV2 OMFT-C-02-FA, SN 24420099, F/W Ver 2.7.0(492), HW Ver 1.10(504,60,1.3.5)
partno?
>> OMFT-C-02-FA
```



## 7 REMOTE CONTROL

This device operates using SCPI standard style commands which are ASCII based and allow easy communication and interpretation with the instrument. Refer to chapter “Board and Connector description” on how to establish communication to the ports available at the instrument. More detailed information on SCPI syntax can be found here: <https://www.ivifoundation.org/downloads/SCPI/scpi-99.pdf>

### 7.1 OPERATING MULTIPLE INTERFACE PORTS

This unit supports parallel usage of all remote-control ports available. Note that responses to commands issued are only returned to the according interface from where the command was issued.

Commands are generally executed in order of time wise arrival to the controller and buffered into an Event queue. If a stack overflow occurs, an error is issued.

Note that there is no control exclusivity for a specific interface or user. Thus, parallel commands issued by different instances will be might lead to inconsistencies. It is therefore recommended to poll current parameter status to ensure integrity of set vs. actual parameters and query the operation complete register (“\*OPC?”) to make sure all previous commands have been executed.

### 7.2 CONNECTION TYPES

There are 2 types of connections that can be used to remote control the unit via SCPI:

1. Connections made with the device can be session based by a raw terminal connection (see 4.2.2) using Port 2000 for Ethernet or a COM Port session (4.2.3.3).
2. Connections through HTTP Service (Port 80). In this case, the SCPI command is encapsulated in the following http request:

`http://<OMFT IP>/scpi/<SCPI-Command>`

A typical example is: `http://omft.local/scpi/*idn?` Which queries the identification string of the unit. The ASCII encoded response is identical to the session-based response.

<wsp> characters defined in the SCPI definitions are to be replaced with ASCII string “%20”. No termination character “;” or <CR> is needed for HTTP based access.

### 7.3 SYNTAX CONVENTIONS FOR COMMANDS

#### 7.3.1 LONG AND SHORT FORM

The key words feature a long form and a short form. Either the short form or the long form can be entered in one command, other abbreviations are not permissible.

Example: “:SYStem:IPADDRess?” is equal to “IPADDR?”

#### NOTE

The short form is marked by upper-case letters; the long form corresponds to the full expression. Upper-case and lower-case notation only serve the above purpose, the instrument itself accept both upper-case and lowercase letters.

#### NOTE

All commands are case insensitive. Long and short form may not be mixed within a single command.

#### 7.3.2 QUERY COMMANDS

Most commands serve a double function that allows either setting or executing a query on a parameter.

#### NOTE

Query commands are terminated by a “?” character.

### 7.3.3 PARAMETER

Parameters must be separated from the header by a “white space”. If several parameters are specified in a command they are separated by a comma “,”.

### 7.3.4 COLON CHARACTER

A leading colon character “:” instructs the instrument to interpret the command starting at the root (highest level) of the command tree. Since the Instrument also starts at the root each time you send it a new command, the leading colon is not required (although the instrument will accept it if you send it).

### 7.3.5 COMMAND TERMINATION CHARACTER

Each command must be terminated either by a “;” character or a carriage return (ASCII #13) to signal completion of the command telegram to the controller.

### ! NOTE

Sending two termination characters is a common mistake causing the unit to respond with “ERR 100;” since the first command is executed once the first termination character is received and the second termination character causes the unit to interpret an empty command. Example:

Command: “volt 1,2;<CR>”

Response “;<CR>ERR 100, unknown command;”

The unit will set BIAS voltage 1 to 2V but additionally receives the empty command which causes the error response.

### 7.3.6 ACKNOWLEDGEMENT OF EXECUTED COMMANDS

The mainframe controller will always acknowledge successful execution of commands by a “;” character. If the echo option is set (for details, see command list), the accordingly sent command is returned first.

### 7.3.7 COMMUNICATION EXAMPLE

Host sends: \*idn?;

unit response: IDP-OMFTV2 OMFT-C-00-FA, SN 19160001, F/W Ver 1.0.0(101), HW Ver 1.00;

### 7.3.8 BASIC SCRIPT EXAMPLE

The following commands can be a minimal script to perform a basic set up of the unit and read the data

COMMAND	COMMENT
INTI;	Initialize Communication settings
*IDN?;	Query idn string of unit
PASS IDP;	Raise user level to 1
*opc?;	Queries if command has been executed (status 1)

Screenshot of script example result:

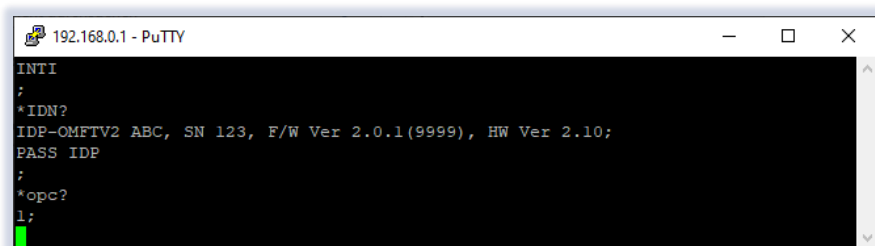

```

192.168.0.1 - PuTTY
INTI
;
*IDN?
IDP-OMFTV2 ABC, SN 123, F/W Ver 2.0.1(9999), HW Ver 2.10;
PASS IDP
;
*opc?
1;

```

<ENTER> was used to execute the command. Alternatively, use “;”. If both is used, it is interpreted as 2 commands of which the second one is empty so that the first command is executed but the second produces an error since empty.



## 7.4 USER ACCESS LEVEL (UAL)

This feature allows execution of commands protected in standard access level to avoid accidental change of important parameters or reboot and shutdown of the unit. See command description

“[:SYStem:]PASSword” for details on how to enable enhanced access.

Custom passwords can be set to the unit for enhanced security requirements. See details in description for “[:SYStem:]SetPASS<wsp>,<P>,<P>”.

**Note:** User access level is granted session based. Each time, a new remote connection is made; the standard User access level 0 is set per default.

USER ACCESS LEVEL (UAL)	PASSWORD
0	-
1	IDP

## 7.5 NOTATION OF SYNTAX FOR COMMAND DEFINITION

SYNTAX AND TYPE	DESCRIPTION
[ ]	An optional command level that can be omitted. For example <code>[:SYStem:]IPADDRess?</code> allows sending the command <code>IPADDR?</code> .
<P>	Denotes a parameter. The placeholder is replaced with the parameter value defined for the corresponding command. For example, the definition <code>[:SYStem:]IPADDRess&lt;WSP&gt;&lt;P&gt;</code> allows setting parameters such as <code>[:SYStem:]IPADDRess 192.168.0.1</code> .
/<P>	Denotes an optional parameter.
;, *	A leading colon (':') instructs the instrument to interpret the command from the root (highest level) of the command tree. However, since the instrument starts at the root each time a new command is sent, the leading colon is optional. The instrument will accept it if included, but it is not required.
<WSP>	Denominates a white space character.
<INT>	Denominates an integer value.

SYNTAX AND TYPE	DESCRIPTION
<FLOAT>	Denominates a float value.
Read/Write (R/W)	Provides information on whether the command reads or writes data.
User Access Level (UAL)	Specifies the User Access Level required to execute the command. It can be either 0 or 1. The password for access level 1 is 'IDP'.
Storage Behavior (SB)	Indicates whether the setting set by the command is saved permanently. Possible values are 0, 1, and 2. 0: Setting is not saved permanently. Any user setting is discarded after reboot. The unit will start with factory defaults upon restart. 1: Setting is saved only after sending command <code>SaveCurrSTATE</code> . The unit will start with this saved setting upon restart. 2: If <code>STArtDEFault</code> is set to 0, this setting is saved immediately upon executing the command. The unit will start with this last setting set by user upon restart. If <code>STArtDEFault</code> is set to 1, the behavior is identical to SB = 0.
Manual Mode (MM)	Indicates whether Manual Mode is required to execute the command: 'x' means Manual Mode is required; '-' means it is not required.

### 7.5.1 CONVENTIONS FOR WRITING TO MULTI-CHANNEL OUTPUTS

For read queries issued to a Multi-Channel output such as the BIAS Electrodes, the interpreter will return the current setting of all channels available, i..e.:

Query `VOLT?`;

Response: `2.34, -5, 6.98, 3.1, 9.99, 12.93;`

For Write Commands, each channel must be set separately by a command. The following example sets the BIAS Voltage for channel 2 to 5.67V:

Command `VOLT 2, 5.67`

Response;;

CHANNEL #	DUALPOL IQ
1	XP
2	XI
3	XQ
4	YP
5	YI
6	YQ
<CH>	This parameter represents the channel. Possible values are {1;2;3;4;5;6}. When used in a query that reads data, the <CH> parameter is optional. If it is omitted, the results for all four ports are shown. Variant 1: Query: <code>FOFFset? 1</code> -> Response: <code>0.00e+00</code> ; (The current offset value of channel 1 is 0) ; Variant 2: Query: <code>FOFFset?</code> -> Response: <code>0.00e+00,0.00e+00,0.00e+00,0.00e+00,0.00e+00,0.00e+00</code> ; (The current offset values of all six channels are 0). In the following examples, we will always use Variant 1.

## 7.6 GENERAL SCPI COMMANDS

SYNTAX
*IDN?
<p>Queries system type and software version. The second section is the part number that is determined by the laser configuration of the actual device and matches the part number printed on the unit's label. The commencing sections include the software version installed and hardware version.</p> <p><b>Response Type:</b> STR e.g.: IDP-OMFTV2 OMFT-C-0x-FA, SN 24440001, F/W Ver 2.4.0(357), HW Ver 1.10(504,4,1.3.5)</p> <p><b>Example:</b> *IDN?</p>
*OPC?
<p>Queries whether all pending commands have been executed. Note that this does NOT indicate whether the physical tuning of laser ports has been completed. Use the <code>busy?</code> query for this.</p> <p><b>Response Type:</b> INT {0;1}</p> <p><b>Example:</b> *OPC?</p>
*WAI
<p>Unit waits to response until <code>*opc?</code> returns 1 and then acknowledges the command. This eliminates the need for a polling loop of <code>*opc?</code> on the remote side.</p> <p><b>Example:</b> *WAI</p>
*RST
<p>Resets the controller, which will perform a warm start of the instrument. All connections and sessions will be closed. Requires user level 1.</p> <p><b>Example:</b> *RST</p>
*CLS
<p>Clears all status and alarm registers of the unit. This command is used to clear latched alarm registers.</p> <p><b>Example:</b> *CLS</p>

## 7.7 COMMANDS ON SYSTEM LEVEL

SYNTAX	R/W	UAL	SB	MM
[ :SYStem: ] INFOrmation?	R	0	0	-
<p>Queries system type and software version. The second section is the part number that is determined by the laser configuration of the actual device and matches the part number printed on the unit's label. The commencing sections include the software version installed and hardware version. This command is equivalent to the <code>*idn?</code> command.</p> <p><b>Response Type:</b> STR e.g.: OMFT: IDP-OMFTV2 OMFT-C-0x-FA, SN 24440001, F/W Ver</p>				

SYNTAX	R/W	UAL	SB	MM
2.4.0 (357), HW Ver 1.10 (504,4,1.3.5) <b>Example:</b> INFO?				
:SYStem:RESet	W	1	0	-
Resets the controller, which will perform a warm start of the instrument. All connections and sessions will be closed. Requires user level 1. This command is equivalent to the <b>*rst</b> command. <b>Example:</b> :SYS:RES				
[ :SYStem: ]ECHO?	R	0	0	-
Queries the echo command's sent status. This setting applies to the current session only. <b>Response Type:</b> INT {0;1} <b>Example:</b> ECHO?				
[ :SYStem: ]ECHO<WSP><P>	W	0	0	-
Sets the echo command's sent status. This setting applies to the current session only. <b>Parameter Type:</b> INT {0;1} <b>Example:</b> ECHO 0				
[ :SYStem: ]FACToryDEFault	W	1	0	x
Resets all parameters saved by SCSTAT back to Factory defaults. <b>Example:</b> FACDEF				
[ :SYStem: ]STArtDEFault?	R	1	0	-
Queries whether the unit starts with the last settings applied before a reboot or with the device's default settings. This affects all settings except the remote interface settings and laser port on/off status. 0 indicates that each change is saved and that the unit restarts with the current configuration upon the next reboot. 1 indicates that the unit always reboots with its factory defaults. <b>Response Type:</b> INT {0;1} <b>Example:</b> STADEF?				
[ :SYStem: ]STArtDEFault<WSP><P>	W	1	2	-
Sets whether the unit starts with the last settings applied before a reboot or with the device's default settings. This affects all settings except the remote interface settings and laser port on/off status. 0 indicates that each change is saved and that the unit restarts with the current configuration upon the next reboot. 1 indicates that the unit always reboots with its factory defaults. <b>Parameter Type:</b> INT {0;1} <b>Example:</b> STADEF 0				
[ :SYStem: ]REMote?	R	0	0	-
Queries the remote status of the device and checks for any open remote sessions via Ethernet. <b>Response Type:</b> INT {0;1} <b>Example:</b> REMO?				
[ :SYStem: ]PASSword?	R	0	0	-

SYNTAX	R/W	UAL	SB	MM
<p>Queries the current user level status.  <b>Response Type:</b> INT {0;1}  <b>Example:</b> PASS?</p>				
[ :SYStem: ] PASSword<WSP><P>	W	0	0	-
<p>Sets a new user level status for this session by sending a password.  <b>Parameter Type:</b> STR  <b>Example:</b> PASS IDP</p>				
[ :SYStem: ] SetPASSword<WSP><P>	W	1	1	-
<p>Sets a password to access the current user level. The current user level must match the level for which the password is being set. The parameter is a string defining the password.  <b>Parameter Type:</b> STR  <b>Example:</b> SPASS IDP</p>				
[ :SYStem: ] INTerfaceInit	W	0	0	-
<p>Resets session parameters to their defaults. Call this after opening the remote port. This command resets ECHO, PASS, FORMAT, unit:X, LINLOG and EVENT.  <b>Example:</b> INTI</p>				
[ :SYStem: ] TIME?	R	0	0	-
<p>Queries the system time. Note that the time is stored in volatile memory only and must be set after each cold start.  <b>Response Type:</b> INT {0;1;...;2147483647}  <b>Example:</b> TIME?</p>				
[ :SYStem: ] TIME<WSP><P>	W	0	0	-
<p>Sets the system time. Note that the time is stored in volatile memory only and must be set after each cold start.  <b>Parameter Type:</b> INT {0;1;...;2147483647}  <b>Example:</b> TIME 946685651</p>				
[ :SYStem: ] ALARm?	R	0	0	-
<p>Queries the alarm status of device. See the "Alarm code definition" section for details.  <b>Response Type:</b> INT {0;1;...;65535}  <b>Example:</b> ALAR?</p>				
[ :SYStem: ] ERROr [ :NEXT ] ?	R	0	0	-
<p>Queries data from the error queue and deletes it.  <b>Example:</b> ERR?</p>				
[ :SYStem: ] FAN?	R	0	0	-
<p>Queries the chassis fan level as a percentage of the maximum level, if a fan is present in the chassis.  <b>Example:</b> FAN?</p>				

SYNTAX	R/W	UAL	SB	MM
[ :SYStem:COMMunicate:]LOCKout?	R	0	0	-
<p>Checks if other sessions are allowed to execute write commands on the unit.  <b>Response Type:</b> INT {0;1}  <b>Example:</b> LOCK?</p>				
[ :SYStem:COMMunicate:]LOCKout<WSP><P>	W	1	0	-
<p>Locks other sessions from performing write commands on the unit. The lock is automatically released if the active session closes.  <b>Parameter Type:</b> INT {0;1}  <b>Example:</b> LOCK 0</p>				
[ :SYStem:COMMunicate:]ParameterREFresh?	R	0	0	-
<p>This query detects any changes made to the unit configuration. Each time the counter increases, it indicates a configuration change. This is useful in multi-user environments to determine if a parallel session has modified the unit's settings.  <b>Response Type:</b> INT {0;1;...;2147483647}  <b>Example:</b> PREF?</p>				
[ :]ABORt	W	0	0	-
<p>Aborts all currently executing pending commands as quickly as possible. Query <b>*OPC?</b> to determine the status once all pending commands have been aborted.  <b>Example:</b> ABOR</p>				
[ :SYStem:]IDENTify<WSP><P>	W	0	0	-
<p>Enables or disables blinking on the unit, allowing identification of the unit controlled by this remote session. This is helpful for installations with multiple ABC units.  <b>Parameter Type:</b> INT {0;1}  <b>Example:</b> IDENT 0</p>				
[ :SCRIPTing:]WAITMilliSeconds<WSP><P>	W	0	0	-
<p>This command causes the unit to wait for specified time until the next command in buffer is executed. This is helpful if a batch of commands is uploaded to the unit for execution. Requires Firmware Version 1.2.1 or later  <b>Parameter Type:</b> INT {0;1;...;60000}  <b>Example:</b> WAITMS 100</p>				
[ :SYStem:]LAYout?	R	0	0	-
<p>Queries the chassis configuration. The response includes the chassis type and lists the installed slots along with the corresponding number of lasers.  <b>Example:</b> LAY?</p>				
[ :SYStem:]INTLock?	R	0	0	-
<p>Queries the status of the interlock setting. The optical output of lasers can only be enabled if the interlock jumper is set. A response of 0 indicates that the laser can be activated.</p>				

SYNTAX	R/W	UAL	SB	MM
<b>Response Type:</b> INT {0;1} <b>Example:</b> INTL?				
[ :SYStem:]CARD:INFOrmation?<WSP><C>,<S>	R	0	0	-
Queries card-level information. The response is identical to the <b>*IDN?</b> query. <b>Example:</b> CARD:INFO? 1,1				
[ :SYStem:]ENABleAUTOSTArt?	R	1	0	-
Queries whether the laser port on/off status is saved and applied upon reboot. <b>Response Type:</b> INT {0;1} <b>Example:</b> ENABAUTOSTA?				
[ :SYStem:]ENABleAUTOSTArt<WSP><P>	W	1	1	-
Enables or disables whether the laser port on/off status is saved and applied upon reboot. <b>Parameter Type:</b> INT {0;1} <b>Example:</b> ENABAUTOSTA 0				
[ :SYStem:]OUTputRANGEselect?	R	0	0	-
Queries the scaling of output BIAS values in the <b>VOLT</b> command. 0: X5 (0 - +5V) ; 1: X1 single-ended (+/-15V) ; 2: X1 differential (+/-30V) ; 3: X5 (+/- 5V) <b>Response Type:</b> INT {0;1;2;3} <b>Example:</b> OUTRANGE?				
[ :SYStem:]OUTputRANGEselect<WSP><P>	W	1	1	x
Scaling of output BIAS values in the <b>VOLT</b> command. 0: X5 (0 - +5V) ; 1: X1 single-ended (+/-15V) ; 2: X1 differential (+/-30V) ; 3: X5 (+/- 5V) <b>Parameter Type:</b> INT {0;1;2;3} <b>Example:</b> OUTRANGE 0				
[ :SYStem:]CSTATus?	R	0	0	-
Queries the current state of BIAS Control. <b>Response Type:</b> STR <b>Example:</b> CSTAT?				
[ :SYStem:]LOSThresh?<WSP>/<CH>	R	0	0	-
This queries the Loss of Signal (LOS) threshold of the unit. If the power at the feedback path drops below the specified value, the ABC stops tracking and a warning is issued. Note that this feature requires a valid power calibration of the feedback path. <b>Example:</b> LOST? 1				

## 7.8 BIAS CONTROL COMMANDS

SYNTAX	R/W	UAL	SB	MM
[ :BIAS: ] AUToStArt?	R	0	0	-
0: Bias Control will remain in Manual mode after startup. 1: Bias Control will automatically run INIT and continue in TRACKING state. <b>Response Type:</b> INT {0;1} <b>Example:</b> AUTST?				
[ :BIAS: ] QuickStArt?	R	0	0	-
Skips INIT state after startup. This option is only recommended if a settled state was saved previously via SCSTAT command. States 1 and 2 are identical. <b>Response Type:</b> INT {0;1;2} <b>Example:</b> QSTA?				
[ :BIAS: ] SETTled?	R	0	0	-
Indicates whether automatic BIAS control has settled (only in TRACKING mode). <b>Response Type:</b> INT {0;1} <b>Example:</b> SETT?				
[ :BIAS: ] VPI? <WSP> / <CH>	R	1	0	-
Queries VPI of BIAS Electrodes. Note: Changing these parameters will impact the performance of the automated control loop. See section "Conventions for writing to multi-channel outputs" for details on the parameter convention. <b>Response Type:</b> FLOAT [V] <b>Example:</b> VPI? 1				
[ :BIAS: ] INIT?	R	0	0	-
Set VPI of BIAS Electrodes. Note: Changing these parameters will impact the performance of the automated control loop. See section "Conventions for writing to multi-channel outputs" for details on the parameter convention. Indicates whether control loop is currently in initialization phase. 1: Init active 0: No Init in progress <b>Response Type:</b> INT {1;2;...;6}, FLOAT [-,V] <b>Example:</b> INIT?				
[ :BIAS: ] INIT	W	0	0	-
Will trigger the initialization routine. 1: Init active 0: No Init in progress <b>Example:</b> INIT				
[ :BIAS: ] MODE?	R	0	0	-
Queries current MZM configuration. 1=DPIQ(1), 2=DPIQ(2), 3=SPIQ(1), 5=DPII(1), 6=DPII(2), 7=SPII(1), 8=custom; Number in brackets denotes the number of feedback photodiodes. See chapter "BIAS Control Loop State Machine" for details. <b>Response Type:</b> INT {1;2;...;8} <b>Example:</b> MODE?				

SYNTAX	R/W	UAL	SB	MM
[ :BIAS: ]MODE<WSP><P>	W	1	0	x
<p>Sets current MZM configuration. 1=DPIQ(1),2=DPIQ(2), 3=SPIQ(1), 5=DPII(1), 6=DPII(2), 7=SPII(1), 8=custom; Number in brackets denotes the number of feedback photodiodes. See chapter chapter “BIAS Control Loop State Machine” for details.</p> <p><b>Parameter Type:</b> {1;2;...;8}</p> <p><b>Example:</b> MODE 1</p>				
[ :BIAS: ]VOLTage?<WSP>/<CH>	R	0	0	-
<p>Query current BIAS voltages. Response will be all 6 BIAS Voltages without Channel ID. See section “Conventions for writing to multi-channel outputs” for details on the parameter convention.</p> <p><b>Response Type:</b> FLOAT, FLOAT, FLOAT, FLOAT, FLOAT, FLOAT [V]</p> <p><b>Example:</b> VOLT? 1</p>				
[ :BIAS: ]VOLTage<WSP><CH><P>	W	0	0	-
<p>Set BIAS Voltages. First Parameter is Channel ID, second is BIAS Voltage to be set to selected electrode. Set is only possible in manual mode. See according table for electrode type assignment. See section “Conventions for writing to multi-channel outputs” for details on the parameter convention.</p> <p><b>Parameter Type:</b> INT {1;2;...;6}, FLOAT [-,V]</p> <p><b>Example:</b> VOLT 1,5.365</p>				
[ :BIAS: ]FOFFset?<WSP>/<CH>	R	0	0	-
<p>Queries the current offset value. Response will be all 6 feedback offsets without Channel ID. See section “Conventions for writing to multi-channel outputs” for details on the parameter convention.</p> <p><b>Response Type:</b> FLOAT, FLOAT, FLOAT, FLOAT, FLOAT, FLOAT [dB]</p> <p><b>Example:</b> FOFF? 1</p>				
[ :BIAS: ]FeedBackDIRection?<WSP>/<CH>	R	0	0	-
<p>Query control loop direction. Response will be 6 Feedback directions without Channel ID. See section “Conventions for writing to multi-channel outputs” for details on the parameter convention.</p> <p><b>Response Type:</b> INT, INT, INT, INT, INT, INT {-1,1}</p> <p><b>Example:</b> FBDIR? 1</p>				
[ :BIAS: ]CHannelACTive?<WSP>/<CH>	R	0	0	-
<p>Queries Control loop for the channel, which can be either active or inactive.</p> <p><b>Response Type:</b> INT, INT, INT, INT, INT, INT {0;1}</p> <p><b>Example:</b> CHACT? 1</p>				
[ :BIAS: ]CHannelASSign?<WSP>/<CH>	R	0	0	-
<p>Assignment of control loop channel to H/W channel. See section “Conventions for writing to multi-channel outputs” for details on the parameter convention.</p> <p><b>Response Type:</b> INT, INT, INT, INT, INT, INT {1;2;...;6}</p> <p><b>Example:</b> CHASS? 1</p>				
[ :BIAS: ]CHannelASSign<WSP><CH><P>	W	0	0	x

SYNTAX	R/W	UAL	SB	MM
<p>Will set control loop channel assignment to different H/W Channel Example: CHASS 1,4; Will assign logical output 1 to Hardware channel 4, logical output 1 is then left unused (0) See section "Conventions for writing to multi-channel outputs" for details on the parameter convention.</p> <p><b>Parameter Type:</b> INT {1;2;...;6}</p> <p><b>Example:</b> CHASS 1,1</p>				
[ :BIAS: ] STAtusVOLTAge?<WSP>/<CH>	R	0	0	-
<p>Queries if any BIAS Voltage is 5% or less to maximum or minimum.</p> <p><b>Response Type:</b> INT {0;1}</p> <p><b>Example:</b> STAVOLT? 1</p>				
[ :BIAS: ] CONTRol?	R	0	0	-
<p>Queries status of automated BIAS Control. 1: Control Active 0: Manual Mode Active</p> <p><b>Response Type:</b> INT {0;1}</p> <p><b>Example:</b> CONT?</p>				
[ :BIAS: ] CONTRol<WSP><P>	W	0	0	-
<p>Sets status of automated BIAS Control. 1: Control Active 0: Manual Mode Active</p> <p><b>Parameter Type:</b> INT {0;1}</p> <p><b>Example:</b> CONT 0</p>				
[ :BIAS: ] OPOWER?<WSP>/<CH>	R	0	0	-
<p>Queries current optical output power in [dBm]. For ABC only: This value is only correct if power calibration was performed before. The optional parameter allows to read only 1 channel. i.e. OPOW? 1; reads the optical power of feedback channel 1.</p> <p><b>Response Type:</b> FLOAT [dBm]</p> <p><b>Example:</b> OPOW? 1</p>				
[ :BIAS: ] MONPower?<WSP>/<CH>	R	0	0	-
<p>Queries current DC feedback level. Note that the unit uses an automated gain switch so that this value cannot be used as a power monitor. The optional parameter allows to read only 1 channel. i.e. OPOW? 1; reads the optical power of feedback channel 1.</p> <p><b>Example:</b> MONP? 1</p>				
[ :BIAS: ] MUTE?	R	0	0	-
<p>Queries MUTE status. If MUTE is active, automated BIAS Control will not change any BIAS Voltage and switch to a low noise mode intended for delicate measurements. A query will also indicate the MUTE status that is set by the external H/W input. 1: Mute Active 0: Standard Operation</p> <p><b>Response Type:</b> INT {0;1}</p> <p><b>Example:</b> MUTE?</p>				
[ :BIAS: ] MUTE<WSP><P>	W	0	0	-
<p>Sets MUTE status. If MUTE is active, automated BIAS Control will not change any BIAS Voltage and switch to a low noise mode intended for delicate measurements. A query will also indicate the MUTE status that is set by</p>				

SYNTAX	R/W	UAL	SB	MM
<p>the external H/W input. 1: Mute Active 0: Standard Operation  <b>Parameter Type:</b> INT {0;1}  <b>Example:</b> MUTE 0</p>				
[ :BIAS:]LOSStatus?	R	0	0	-
<p>Queries if output power of device is too low for automatic BIAS Control. 1: Loss of Signal (LOS) - Signal too low. Control loops stops. ; 0: Signal within valid range Note that this feature requires a valid power calibration of the feedback path.  <b>Response Type:</b> INT {0;1}  <b>Example:</b> LOSS?</p>				
[ :BIAS:]MAXRange?	R	1	0	-
<p>Queries maximum Voltage applied to BIAS electrodes in [V]. Setting is possible only with User Access Level 1 or higher and in MANUAL mode of BIAS control. This value can be between 0V and 48V.  <b>Response Type:</b> FLOAT {0;...;48} [ V]  <b>Example:</b> MAXR?</p>				
[ :BIAS:]MAXRange<WSP><P>	W	1	0	x
<p>Sets maximum Voltage applied to BIAS electrodes in [Volts]. Setting is possible only with User Access Level 1 or higher and in MANUAL mode of BIAS control. This value can be between 0V and 48V.  <b>Parameter Type:</b> FLOAT {0;...;48}  <b>Example:</b> MAXR 0</p>				
[ :BIAS:]HWMAXRange?	R	1	0	-
<p>Queries Voltage setting of HARDWARE. This is the maximum Voltage range addressable by the hardware in [V]. This value can be 12,24 or 48V. This value is automatically set by the S/W, following HWMAXRange &gt; MAXRange.  <b>Response Type:</b> INT {12;24;48} [V]  <b>Example:</b> HWMAXR?</p>				
[ :BIAS:]TRackInLOS?	R	1	0	-
<p>If enabled(1), control loop is forced to continue operating even if LOS alarm is present. CAUTION: The control loop will drift away if no feedback signal is present (i.e. no photodiode connected).  <b>Response Type:</b> INT {0;1}  <b>Example:</b> TRILOS?</p>				
[ :BIAS:]TRackInLOS<WSP><P>	W	1	0	-
<p>If enabled(1), control loop is forced to continue operating even if LOS alarm is present. CAUTION: The control loop will drift away if no feedback signal is present (i.e. no photodiode connected).  <b>Parameter Type:</b> INT {0;1}  <b>Example:</b> TRILOS 0</p>				
[ :BIAS:]UNWrapThresh?	R	0	0	-
<p>(Firmware 1.5.1 or later) Will set set threshold at which unwrap of BIAS electrodes is triggered.</p>				

SYNTAX	R/W	UAL	SB	MM
<b>Response Type:</b> FLOAT {0;100} <b>Example:</b> UNWT?				

## 7.9 RF AMPLIFIER CONTROL COMMANDS

SYNTAX	R/W	UAL	SB
[ :TransX:]AMPPeaking?	R	0	0
Queries peaking level of Transmitter RF Amplifiers. <b>Response Type:</b> INT {0;1;...;255} <b>Example:</b> AMPP?			
[ :TransX:]AMPPeaking<WSP><CH><P>	W	0	2
Sets peaking level of Transmitter RF Amplifiers. <b>Parameter Type:</b> INT {1;2;3;4}, INT {0;1;...;255} <b>Example:</b> AMPP 1,3			
[ :TransX:]AMPGain?	R	0	0
Queries gain level of Transmitter RF Amplifiers. <b>Response Type:</b> INT {0;1;...;255} <b>Example:</b> AMPG?			
[ :TransX:]AMPGain<WSP><CH><P>	W	0	2
Sets gain level of Transmitter RF Amplifiers. <b>Parameter Type:</b> INT {1;2;3;4}, INT {0;1;...;255} <b>Example:</b> AMPG 1,2			
[ :TransX:]AMPSquelch?	R	0	0
Queries if squelching of the RF Amplifier is en- or disabled. <b>Response Type:</b> INT {0;1} <b>Example:</b> AMPSQ?			
[ :TransX:]AMPSquelch<WSP><P>	W	0	0
En- or disables squelching of the RF Amplifier. <b>Parameter Type:</b> INT {0;1} <b>Example:</b> AMPSQ 0			
[ :TransX:]PEQualizer?	R	0	0
Queries the relative power between X Polarization and Y Polarization by attenuating one polarization. <b>Response Type:</b> INT {0;1;...;100} <b>Example:</b> PEQU?			

SYNTAX	R/W	UAL	SB
[ :TransX: ] PEQUalizer<WSP><P>	W	0	0
Sets the relative power between X Polarization and Y Polarization by attenuating one polarization <b>Parameter Type:</b> INT {0;1;...;100} <b>Example:</b> PEQU 0			
[ :TransX: ] TFREQuency?	R	0	0
Queries the operating frequency of the IQ MZM. It will internally apply a calibration to optimize performance for this particular frequency. <b>Response Type:</b> FLOAT [THz] <b>Example:</b> TFREQ?			
[ :TransX: ] TFREQuency<WSP><P>	W	0	2
Sets the operating frequency of the IQ MZM. It will internally apply a calibration to optimize performance for this particular frequency. <b>Parameter Type:</b> FLOAT [THz] <b>Example:</b> TFREQ 193.4			
[ :TransX: ] TWAVelength?	R	0	0
Queries the oparting wavelength of the IQ MZM. It will internally apply a calibration to optimize performance for this particular wavelength. <b>Response Type:</b> FLOAT [nm] <b>Example:</b> TWAV?			
[ :TransX: ] TWAVelength<WSP><P>	W	0	0
Sets the oparting wavelength of the IQ MZM. It will internally apply a calibration to optimize performance for this particular wavelength. <b>Parameter Type:</b> FLOAT [nm] <b>Example:</b> TWAV 1550.1			
[TransX:]preSOAONOFF?	R	1	0
Queries the SOA status, where 0 indicates 'off' and 1 indicates 'on'. <b>Response Type:</b> INT {0;1} <b>Example:</b> SOAONOFF?			
[TransX:]preSOAONOFF<WSP><P>	W	1	0
Sets the SOA status, where 0 indicates 'off' and 1 indicates 'on'. <b>Response Type:</b> INT {0;1} <b>Example:</b> SOAONOFF 0			

## 7.10 TUNABLE LASER CONTROL COMMANDS

Note that the following commands are only available if the internal tunable laser option is installed.

SYNTAX	R/W	UAL	SB
[ :SOURce: ] TYPe?<WSP><C>, <S>, <D>	R	0	0
<p>Queries the laser type present at the specified location. Use the wildcard * to retrieve the full chassis inventory. When using a wildcard, port coordinates are also included in the response. Example: Command -&gt; <code>type? 1,1,1</code>            Response -&gt; NC  <b>Response Type:</b> STR  <b>Example:</b> TYP? 1,1,1</p>			
[ :SOURce: ] WAVelength?<WSP><C>, <S>, <D>	R	0	0
<p>Queries the wavelength setting of a tunable laser port. The value is provided in nanometers (nm).  <b>Response Type:</b> FLOAT [nm]  <b>Example:</b> WAV? 1,1,1</p>			
[ :SOURce: ] WAVelength<WSP><C>, <S>, <D>, <P>	W	0	0
<p>Sets the wavelength setting of a tunable laser port. The value is provided in nanometers (nm). Example: <code>WAV 1550.012</code>; sets Laser Port 1,1,1 to 1550.012nm. Use the <code>WAVelength:LIMit?</code> command to get the wavelength limits of your device.  <b>Parameter Type:</b> FLOAT [nm]  <b>Example:</b> WAV 1,1,1,1550.012</p>			
[ :SOURce: ] WAVelength:LIMit?<WSP><C>, <S>, <D>	R	0	0
<p>Queries the wavelength setting limits of a tunable laser port. The values are provided in nanometers (nm).            Example: Command -&gt; <code>WAV:LIM?</code>; (queries Laser Port 1,1,1) Response -&gt; 1528,1565; (minimum and maximum limits)  <b>Response Type:</b> FLOAT, FLOAT [nm, nm]  <b>Example:</b> WAV:LIM? 1,1,1</p>			
[ :SOURce: ] FREQuency?<WSP><C>, <S>, <D>	R	0	0
<p>Queries the frequency setting of a tunable laser port. The value is provided in terahertz (THz).  <b>Response Type:</b> FLOAT [THz]  <b>Example:</b> FREQ? 1,1,1</p>			
[ :SOURce: ] FREQuency<WSP><C>, <S>, <D>, <P>	W	0	2
<p>Sets the frequency setting of a tunable laser port. The value is provided in terahertz (THz). Example: <code>FREQ 192.15</code>; sets Laser Port 1,1,1 to 192.15THz. Use the <code>FREQuency:LIMit?</code> command to check the frequency limits of your device.  <b>Parameter Type:</b> FLOAT [THz]  <b>Example:</b> FREQ 1,1,1,192.15</p>			
[ :SOURce: ] FREQuency:LIMit?<WSP><C>, <S>, <D>	R	0	0
<p>Queries the frequency setting limits of a tunable laser port. The values are provided in terahertz (THz). Example:</p>			

SYNTAX	R/W	UAL	SB
Command -> <b>FREQ:LIM?</b> ; (queries Laser Port 1,1,1) Response -> 191.1020,196.1020; (minimum and maximum limits) <b>Response Type:</b> FLOAT, FLOAT [THz, THz] <b>Example:</b> FREQ:LIM? 1,1,1			
[:SOURce:]OFFset?<WSP><C>, <S>, <D>	R	0	0
Queries the frequency offset setting of a tunable laser port. The value is provided in gigahertz (GHz). <b>Response Type:</b> FLOAT [GHz] <b>Example:</b> OFF? 1,1,1			
[:SOURce:]OFFset<WSP><C>, <S>, <D>, <P>	W	0	2
Sets the frequency offset setting of a tunable laser port. The value is provided in gigahertz (GHz). Example: <b>OFF 11.15</b> ; sets Laser Port 1,1,1 offset to 11.15 GHz. Value can be positive or negative. Use the <b>OFFset:LIMit?</b> command to get the offset limits of your device. <b>Parameter Type:</b> FLOAT [GHz] <b>Example:</b> OFF 1,1,1,11.15			
[:SOURce:]OFFset:LIMit?<WSP><C>, <S>, <D>	R	0	0
Queries the offset setting limits of a tunable laser port. The value is provided in gigahertz (GHz) Example: Command -> <b>OFF:LIM?</b> ; (queries Laser Port 1,1,1) Response -> 12; (a single value, as the offset is symmetrical to 0) <b>Response Type:</b> FLOAT [GHz] <b>Example:</b> OFF:LIM? 1,1,1			
[:SOURce:]POWer?<WSP><C>, <S>, <D>	R	0	0
Queries the optical output power target setting of a tunable laser port. The value is provided in dBm. <b>Response Type:</b> FLOAT [dBm] <b>Example:</b> POW? 1,1,1			
[:SOURce:]ActualPOWer?<WSP><C>, <S>, <D>	R	0	0
Queries the current optical output power reading of a tunable laser port. The value is provided in dBm. Example: Command-> <b>APOW?</b> ; (queries the Laser Port 1,1,1) Response -> 11.15 (indicating 11.15 dBm) <b>Response Type:</b> FLOAT [dBm] <b>Example:</b> APOW? 1,1,1			
[:SOURce:]POWer<WSP><C>, <S>, <D>, <P>	W	0	0
Sets the optical output power target setting of a tunable laser port. The value is provided in dBm. Example: POW 11.15; sets the power of Laser Port 1,1,1 to 11.15 dBm. Use the <b>POWer:LIMit?</b> command to get the power limits of your device. <b>Parameter Type:</b> FLOAT [dBm] <b>Example:</b> POW 1,1,1,11.15			
[:SOURce:]POWer:LIMit?<WSP><C>, <S>, <D>	R	0	0
Queries the output power setting limits of a tunable laser port. The values are provided in dBm. Example:			

SYNTAX	R/W	UAL	SB
Command -> <b>POW:LIM?</b> ; (queries Laser Port 1,1,1) Response -> 9.50,15.50; (minimum and maximum limits) <b>Response Type:</b> FLOAT, FLOAT [dBm, dBm] <b>Example:</b> POW:LIM? 1,1,1			
[:SOURCE:] STATE?<WSP><C>, <S>, <D>	R	0	0
Queries whether the laser port is on (1) or off (0). <b>Response Type:</b> INT {0;1} <b>Example:</b> STAT? 1,1,1			
[:SOURCE:] STATE<WSP><C>, <S>, <D>, <P>	W	0	2
Switches the laser port on (1) or off (0). <b>Parameter Type:</b> INT {0;1} <b>Example:</b> STAT 1,1,1,0			
[:SOURCE:] LIMit?<WSP><C>, <S>, <D>	R	0	0
Queries the maximum tuning parameters of the laser at location C-S-D in CSV format. <Minimum Frequency>,<Maximum Frequency>,<Fine tuning Range>,<Minimum Power>,<Maximum Power> Example: Command -> <b>LIM?</b> ; (queries Laser Port 1,1,1) Response -> 191.1000,196.2500,6.000,9.50,15.50; <b>Response Type:</b> FLOAT, FLOAT, FLOAT, FLOAT, FLOAT [THz, THz, GHz, dBm, dBm] <b>Example:</b> LIM? 1,1,1			
[:SOURCE:] CONFIguration?<WSP><C>, <S>, <D>	R	0	0
Queries the current configuration of the laser at location C-S-D in CSV format: <Frequency>,<Offset>,<Output Power>,<Output state>,<Busy state>,< Dither state>; Busy State (INT): 1 (busy), 0 (not busy) ; Dither State (INT): 1 (enabled), 0 (disabled), -1 (not supported) If queried and -1 is reported, the laser does not support this feature. If set and the laser does not support the feature, the parameter must be -1. Example: Command -> <b>SOUR:CONF? 1,2,3</b> ; Response -> 191.42,10.134,6.12,0,1,-1; Interpretation: The laser is set to 191.42 THz, 10.134 GHz fine-tuning offset, 6.12dBm output power, output off (0) , busy tuning (0), dither not supported(-1) <b>Response Type:</b> FLOAT, FLOAT, FLOAT, INT, INT, INT [THz, GHz, dBm, -, -, -] <b>Example:</b> CONF? 1,1,1			
[:SOURCE:] CONFIguration<WSP><C>, <S>, <D>, <P><P><P><P><P>	W	0	0
Sets the current configuration of the laser at location C-S-D in CSV format: <Frequency>,<Offset>,<Output Power>,<Output state>,< Dither state>, Dither State (INT): 1 (enabled), 0 (disabled), -1 (not supported); If queried and -1 is returned, the laser does not support this feature. If setting the parameter and the laser does not support the feature, the value must be -1. Example: Command -> <b>SOUR:CONF 1,1,1,193,1,7,1,-1</b> ; will set the frequency to 193 THz,the fine-tuning offset to 1 GHz,the output power to 7dBm, 1: laser on (1): dither not supported(-1). Note: For SC Type lasers, frequency and offset cannot be changed within a single command. Use two separate commands to set them individually. <b>Parameter Type:</b> FLOAT, FLOAT, FLOAT, INT, INT [THz, GHz, dBm, -, -] <b>Example:</b> CONF 1,1,1,193,1,7,1,-1			
[:SOURCE:] BUSY?<WSP><C>, <S>, <D>	R	0	0
Queries if the laser port is currently tuned (1) or settled (0).			

SYNTAX	R/W	UAL	SB
<b>Response Type:</b> INT {0;1} <b>Example:</b> BUSY? 1,1,1			
[:SOURCE:]MONitor?<WSP><C>,<S>,<D>	R	0	0
<p>Queries monitor readings from the laser. The response includes the following parameters: LD Chip Temperature (°C), format: nn.nn ; LD Base Temperature (°C), format: nn.nn; LD Chip Current (mA), format: nnnn.n ; TEC Current (mA), format nnnn.n Example: Command -&gt; MON? 1,2,3; Response -&gt; 29.23,25.12,125.1,1043.2; Interpretation: LD Chip Temperature: 29.23°C ; LD Base Temperature: 25.12°C ; LD Chip Current: 125.1 mA ; TEC Current: 1043.2 mA</p> <p><b>Response Type:</b> FLOAT, FLOAT, FLOAT, FLOAT [ °C, °C, mA, mA]  <b>Example:</b> MON? 1,1,1</p>			

### 7.11 SCPI CODE ERROR DEFINITION

ERROR #	DESCRIPTION
100	Invalid SCPI Command: i.e. wrong parameter, parameter out of range or device is incompatible.
102	Invalid SCPI Command due to an illegal parameter.
200	Occurs when the SCPI command cannot be executed due to settings or the current system state; so far, this only occurs with 'SOAONOFF 1' when the laser is not switched on.
201	Occurs if the SCPI authentication level ( = user access level / UAL) is insufficient for the command (i.e., the required 'pass xxx' is missing).
202	Occurs when the internal command queue overflows.
204	Occurs when VPISearch or offset measurement cannot be completed.
205	Occurs when VPISearch or offset measurement cannot be completed.
206	Occurs when VPISearch or offset measurement cannot be completed.
207	Occurs if 'Lock' is set using the LOCK command.
208	Occurs when a command requires MANUAL_MODE, but the system is in a different mode.
224	Error during the offset measurement.
225	Occurs when an OMFT-specific command is to be executed on an ABC device.
226	Occurs if CDM is not available or shut down.
227	Occurs when a Class 80G module is required but a different module is installed.

## 7.12 ALARM CODE DEFINITION

BIT #	ALARM	CONDITION/DESCRIPTION
0	BIAS Value at limit	The BIAS settings of modulator are close to limit.
1	Init error	The initialization of Automatic BIAS Control failed.
2	Feedback signal warning	The feedback for Automatic BIAS Control failed.
3	Gain error, feedback signal too low or too large	The gain of the feedback circuit for the Automatic BIAS Control failed.
4	generic Fault	A general error occurred.
5	H/W error	A hardware related error occurred.
6	Reserved	
7	DC signal warning	The photocurrent of the Automatic BIAS Control feedback is high. This alarm occurs only if no LOS is present.
8	Input Signal warning PHD1	The photocurrent of the Automatic BIAS Control feedback 1 is high.
9	Input Signal warning PHD2	The photocurrent of the Automatic BIAS Control feedback 2 is high.
10	Start Init search failed	The start procedure of the Automatic BIAS Control failed.
11	FB Fail	The feedback for the Automatic BIAS Control failed.
12	Laser Fail	Due to a laser failure.
13	IQMOD Failure	Due to a modulator failure.
14	Reserved	
15	Reserved	

# 8 APPENDIX

## 8.1 REFERENCE SETTINGS FOR KEYSIGHT AWGS

These settings are provided for reference for a standard setup to enable a quick start. For any further details on the AWG and this software, contact Keysight support.

For this typical setup, we recommend the OMFT Gain settings of ~ 30% (Class40) or 70% (Class 60) and peaking between 0% and 50%.

Block Diagram of a typical setup

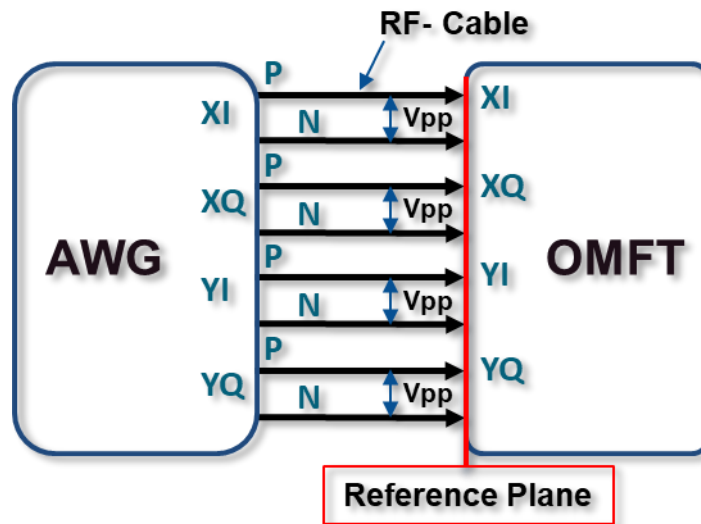

Output Settings for an AWG, 250mVpp differential, 0V offset, screenshot from Keysight Software.

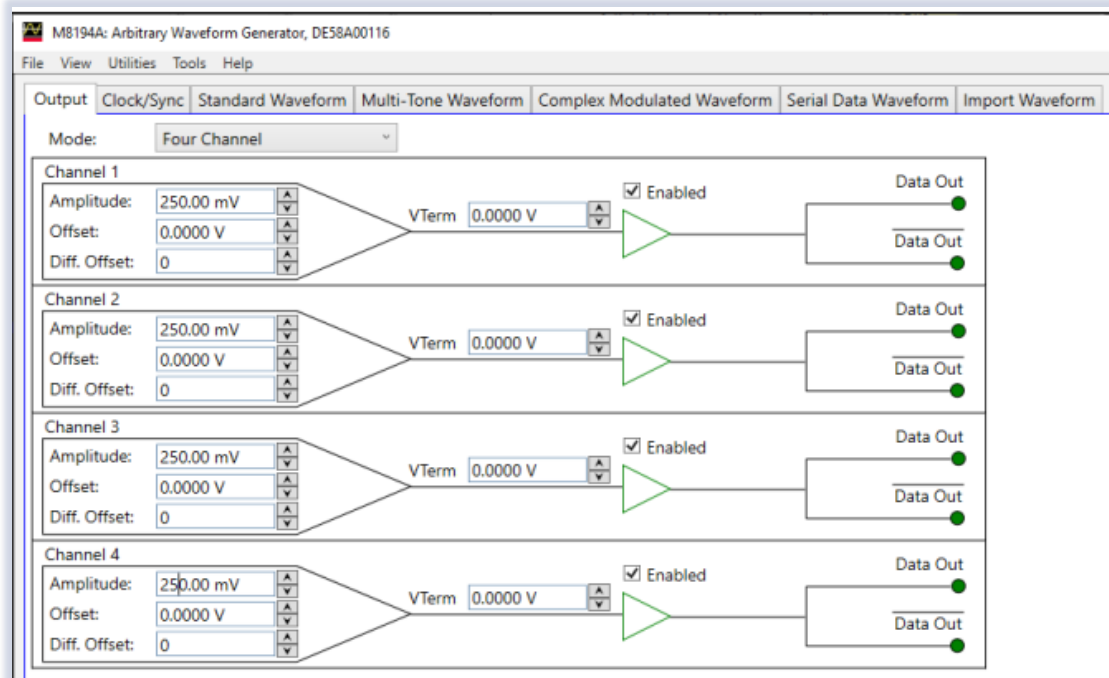

For single ended operation, make sure to properly terminate the unused RF Ports with 50 Ohm and double the output swing from the AWG to 500mV.

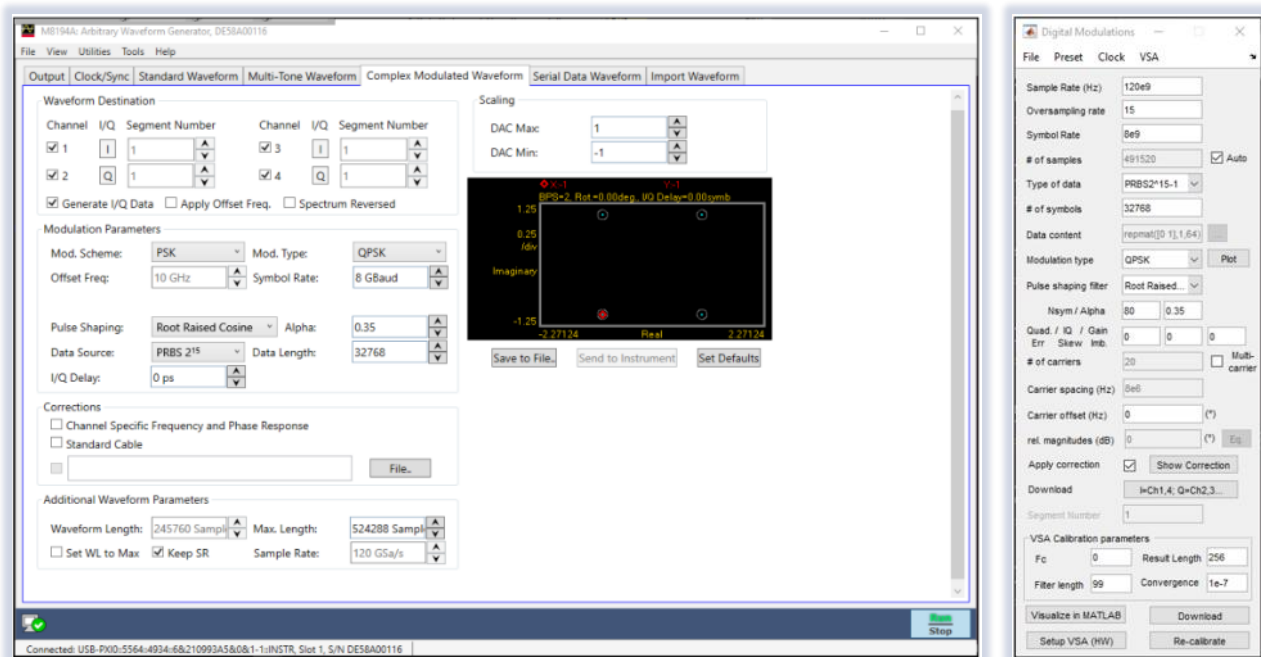
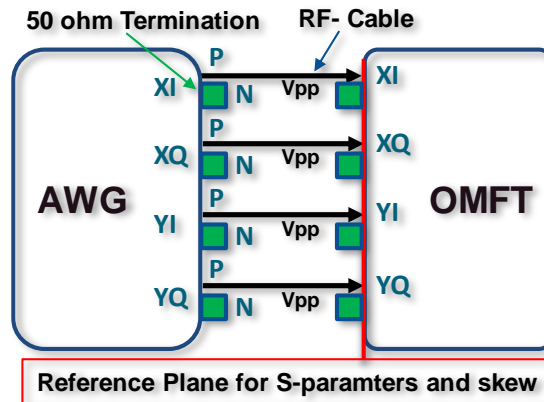

Reference Settings for the free Keysight “IQ Tool” to generate a DP-QPSK Signal

## 8.2 MANUAL OPERATION OF OMFT

Although the OMFT is designed to operate in automatic bias mode, it is useful to understand the impact of the modulator bias settings on the generated optical signal.

For this purpose, the user can set the OMFT to manual bias mode.

The following steps describe how to adjust the modulator bias voltages manually. It is recommended to perform the manual adjustment with NRZ-QPSK signals. Furthermore, it is assumed that the user has set up the OMFT with an output monitor coupler to record the optical output spectrum of the OMFT using a high-resolution optical spectrum analyzer (OSA) such as the ID Photonics ID OSA as well as a sampling oscilloscope (DCA) with a fast photo detector to view the optical envelope.

### 8.2.1 ADJUST THE BIAS VOLTAGES (“X-I”, “X-Q”, “Y-I” AND “Y-Q”) USING THE OSA:

On the OSA a spectrum for NRZ-QPSK, similar to the one shown in the figure below, should be seen. Change the bias voltages for “X-I”, “X-Q”, “Y-I” and “Y-Q” via the GUI to minimize the clock lines (marked by red circles in the figure below) as well as the residual CW carrier in the center of the spectrum. The clock lines can be suppressed as

shown in the figure in the optimum case. If not, the RF drive signals might have some skew, which needs to be de-skewed first (8.2.3 De-skewing of RF Drive ).

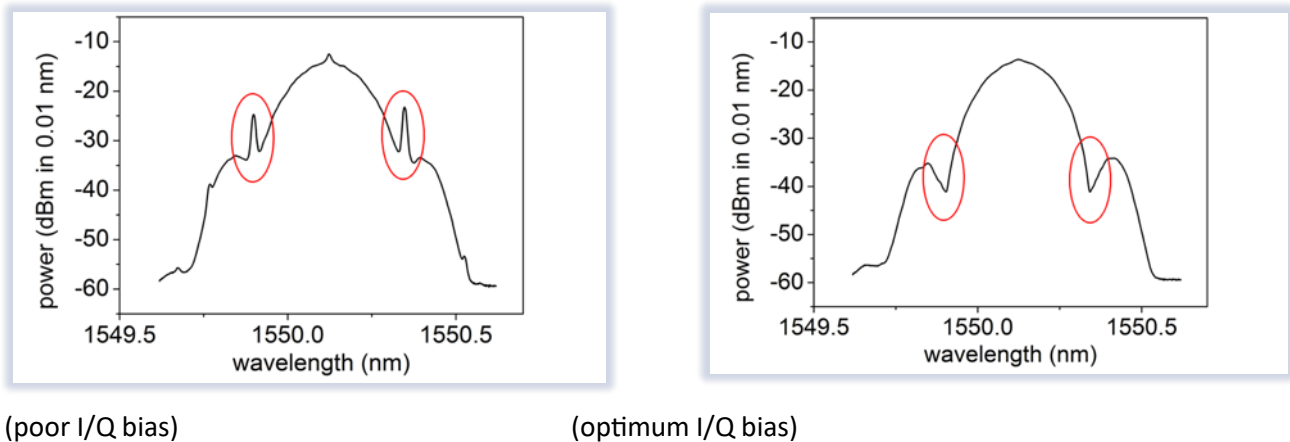

Figure 1: Optical spectrum for NRZ-QPSK at the output of the OMFT for poor (left) and optimum (right) setting of the I and Q modulator bias voltages.

### 8.2.2 ADJUST THE BIAS VOLTAGE FOR “X-PHASE” AND “Y-PHASE” USING THE DCA

On the DCA a picture similar to the one shown below should appear. Change the bias voltage for “X-Phase” and “Y-Phase” via the GUI to minimize the standard deviation of the high intensity level of the envelope on the DCA. An optimum optical envelope is shown in the following figure (measured for NRZ PDM-QPSK at 28 Gbd with the DCA). If the DCA envelope exhibits more features, double rails or alike, the RF drive signals might be too large or have some skew, which needs to be de-skewed first (see section 8.2.3 De-skewing of RF Drive ).

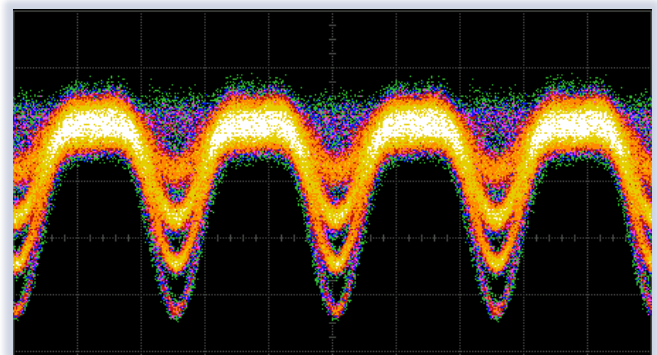

Figure 2: Optical envelope for NRZ PDM-QPSK at the output of the OMFT for optimum setting of the modulator phase bias voltage.

Finally, go back to section 8.2.1 to check if the clock lines in the optical spectrum are still well suppressed. If not, continue the manual adjustment procedure iteratively between section 8.2.1 and 8.2.2 (including possibly an RF drive signal de-skew (see section 8.2.3 De-skewing of RF Drive ).

After manual optimization of the modulator bias settings, it is recommended to save these settings using the save button of the GUI.

#### ! NOTE

The optimum bias voltages strongly depend on the ambient parameters such as the temperature, temperature drift, and the RF-drive amplitude. A slight drift can occur during several hours, leading to non-optimal performance. In this case a re-adjustment of the bias voltages is recommended.

### 8.2.3 DE-SKEWING OF RF DRIVE SIGNALS

One reason that the optical spectrum and optical envelope cannot be well optimized by the modulator bias voltages is that the RF drive signals might have a skew (intra-bit skew between the driving signals). Follow the following steps to perform a de-skew of the signals using the DCA:

- Turn-on the RF amplifier for the “X-I”-input only. Use the horizontal time delay knob of the DCA to move a characteristic point of the optical envelope (e. g. the minimum intensity at the symbol transition) to the center of the screen.
- Next, turn-off this amplifier and turn-on the next amplifier (“X-Q”-input). A similar picture as before should appear on the DCA screen, but the characteristic point of the envelope might not be located at the center of the screen. DO NOT touch the DCA delay adjustment knob during the procedure. Now adjust the delay between your electrical data source and the “X-Q”-input of the OMFT (e. g. by re-programming the respective output of your electrical data source or by using an electrical phase shifter between the source and the OMFT input) to move the characteristic point of the envelope to the center again. This will de-skew the delay of “X-Q” with respect to the “X-I” input.

 **NOTE**

The intra-bit skew adjustment may depend on the symbol rate. Therefore, the intra-bit skew adjustment has to be re-done each time the symbol rate is changed.

- Repeat this procedure for “Y-I” and “Y-Q”, so that all four RF-channels are de-skewed. DO NOT touch the DCA delay adjustment knob during the procedure.



IDPHOTONICS<sup>GMBH</sup>

**SHAPING LIGHT.**

HELPING ENGINEERS AND  
SCIENTISTS IN  
ADVANCING HOW THE  
WORLD COMMUNICATES,  
SENSES AND CONNECTS



TUNABLE  
LASER



TRANSMITTER  
SOLUTIONS

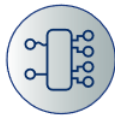

RECEIVER  
SOLUTIONS



SPECTRAL  
ANALYSIS



Anton-Bruckner-Strasse 6  
85579 Neubiberg  
GERMANY  
Tel: +49-89-201 899 16  
info@id-photonics.com  
id-photonics.com

All rights reserved. No part of this publication may be reproduced, stored in a retrieval system or transmitted in any form, be it electronically, mechanically, or by any other means such as photocopying, recording or otherwise, without the prior written permission of ID Photonics GmbH. Information provided by ID Photonics GmbH is believed to be accurate and reliable. However, no responsibility is assumed by ID Photonics GmbH for its use nor for any infringements of patents or other rights of third parties that may result from its use. No license is granted by implication or otherwise under any patent rights of ID Photonics GmbH. The information contained in this publication is subject to change without notice.